

Portal Frame Flange Brace Details

AJ0050 - TYP FLANGE BRACE AT BU COL & PORTAL COL

AJ0051 - TYP FLANGE BRACE AT BU COL & NESTED PORTAL COL

AJ0055 - ALT FLANGE BRACE AT BU COL & PORTAL COL

AJ0056 - ALT FLANGE BRACE AT BU COL & NESTED PORTAL COL

AJ0050 - FLANGE BRACE AT COLUMN & PORTAL COLUMN

[Download the DWG file by clicking here.](#)

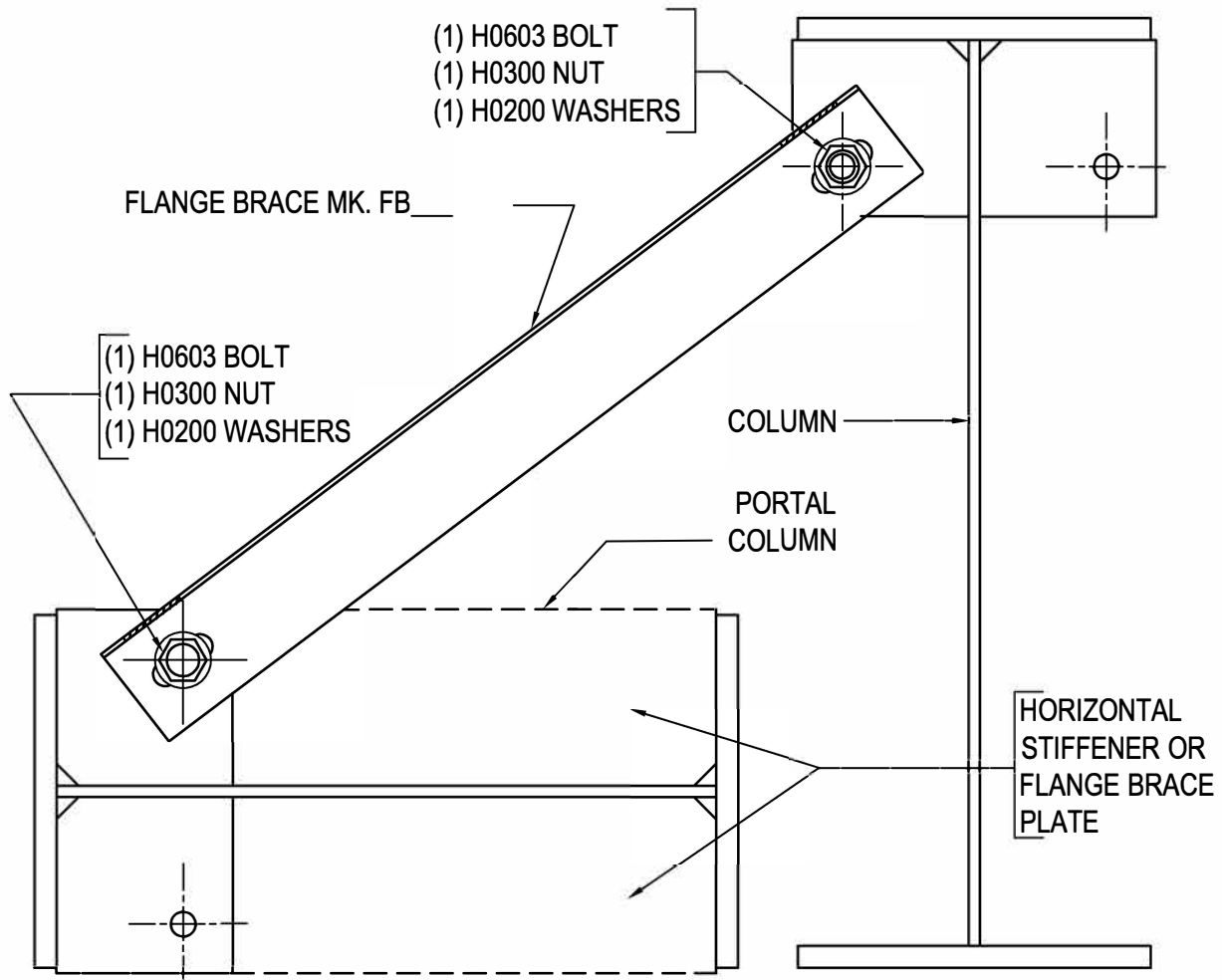

FLANGE BRACE AT COLUMN & PORTAL COLUMN

SEE PLANS AND ELEVATIONS FOR FLANGE BRACE PART MARKS

AJ0050

Detailer Notes:

- 1) DO NOT CONNECT THE FLANGE BRACE TO THE COLUMN CAP PLATE.

AJ0051 - FLANGE BRACE AT COLUMN & NESTED PORTAL COLUMN

[Download the DWG file by clicking here.](#)

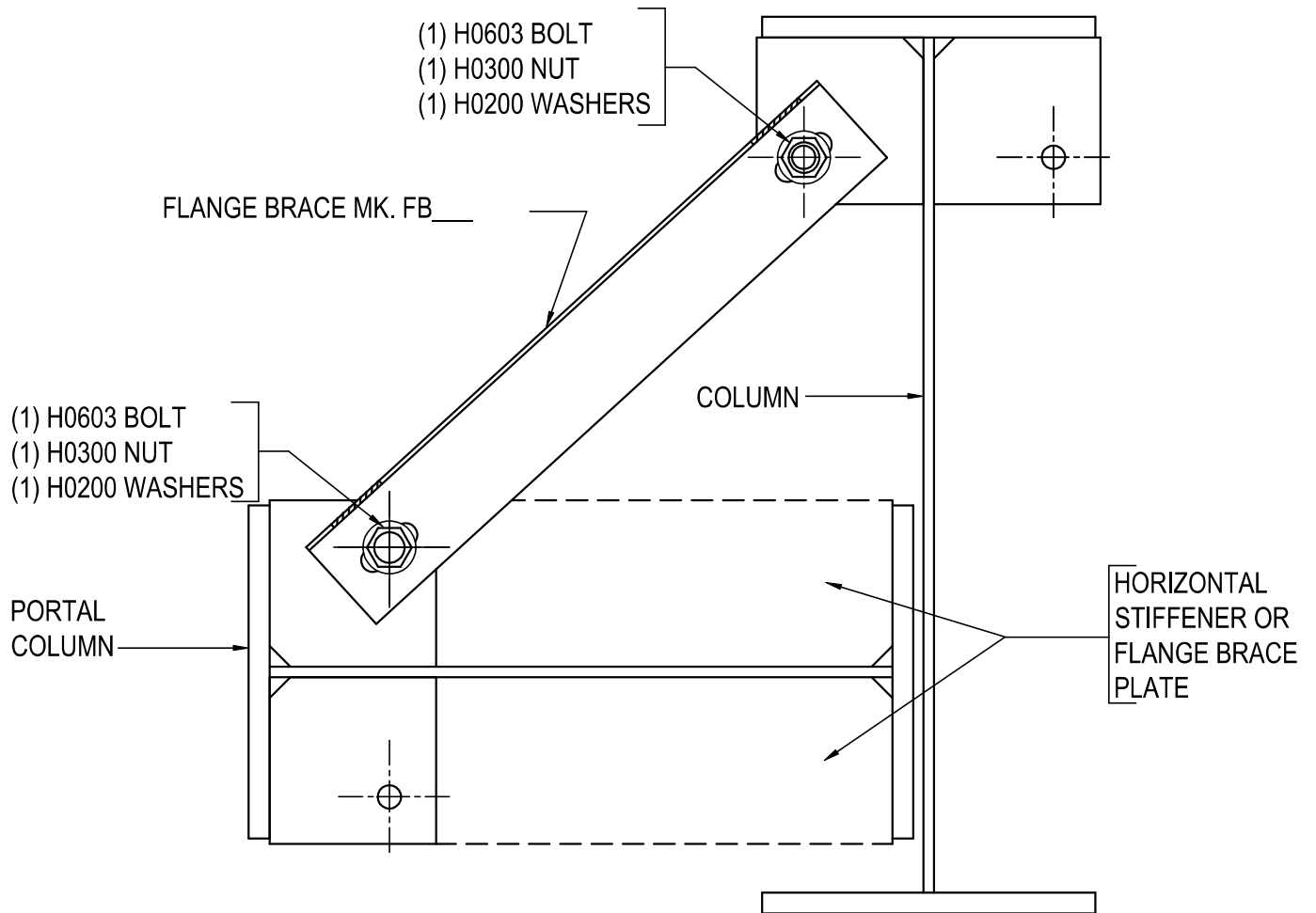

FLANGE BRACE AT COLUMN & NESTED PORTAL COLUMN

SEE PLANS AND ELEVATIONS FOR FLANGE BRACE PART MARKS

AJ0051

Detailer Notes:

- 1) DO NOT CONNECT THE FLANGE BRACE TO THE COLUMN CAP PLATE.

AJ0055 - ALT FLANGE BRACE AT COLUMN & PORTAL COLUMN

[Download the DWG file by clicking here.](#)

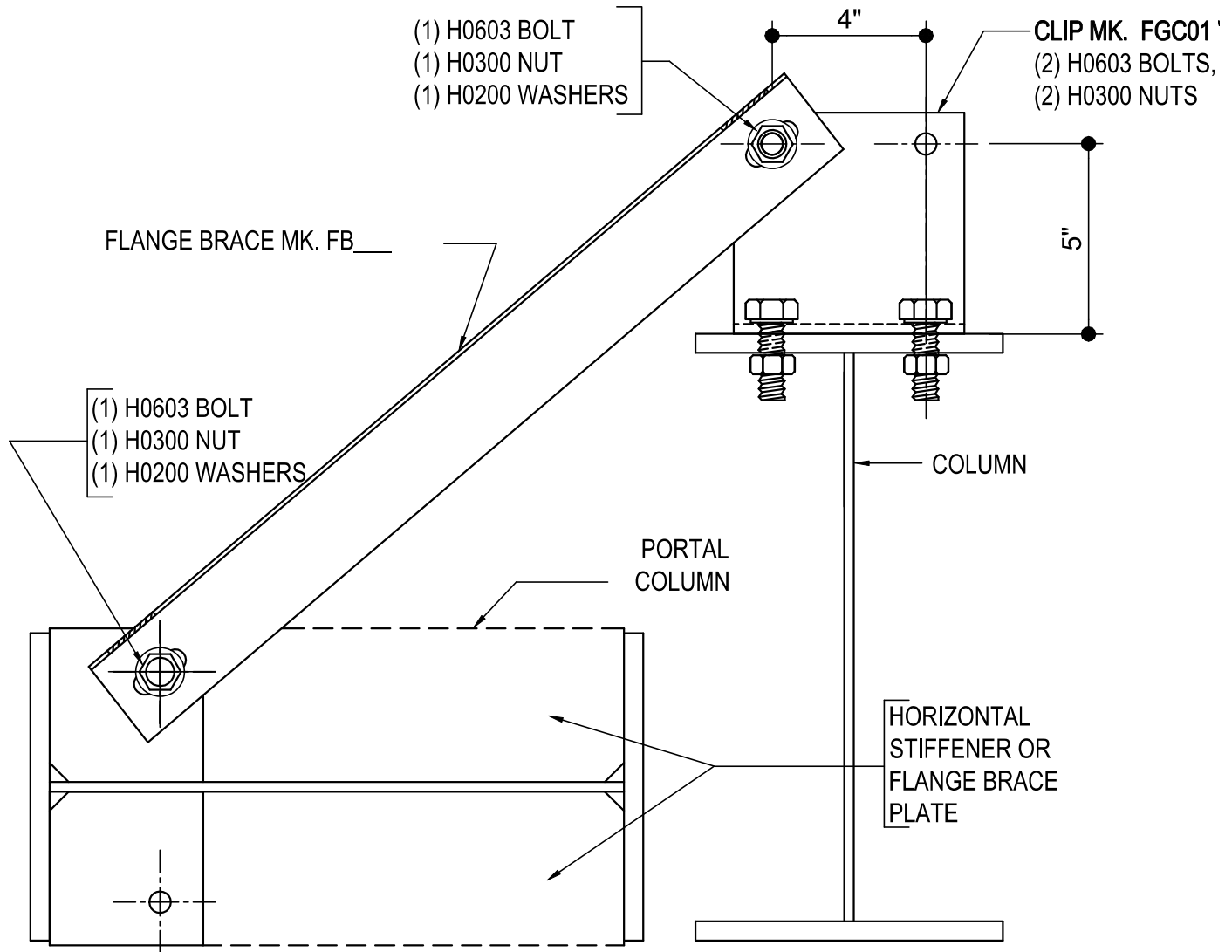

ALT FLANGE BRACE AT COLUMN & PORTAL COLUMN

SEE PLANS AND ELEVATIONS FOR FLANGE BRACE PART MARKS

AJ0055

Detailer Notes:

- 1) DO NOT CONNECT THE FLANGE BRACE TO THE COLUMN CAP PLATE.

AJ0056 - ALT FLANGE BRACE AT COLUMN & NESTED PORTAL COLUMN

[Download the DWG file by clicking here.](#)

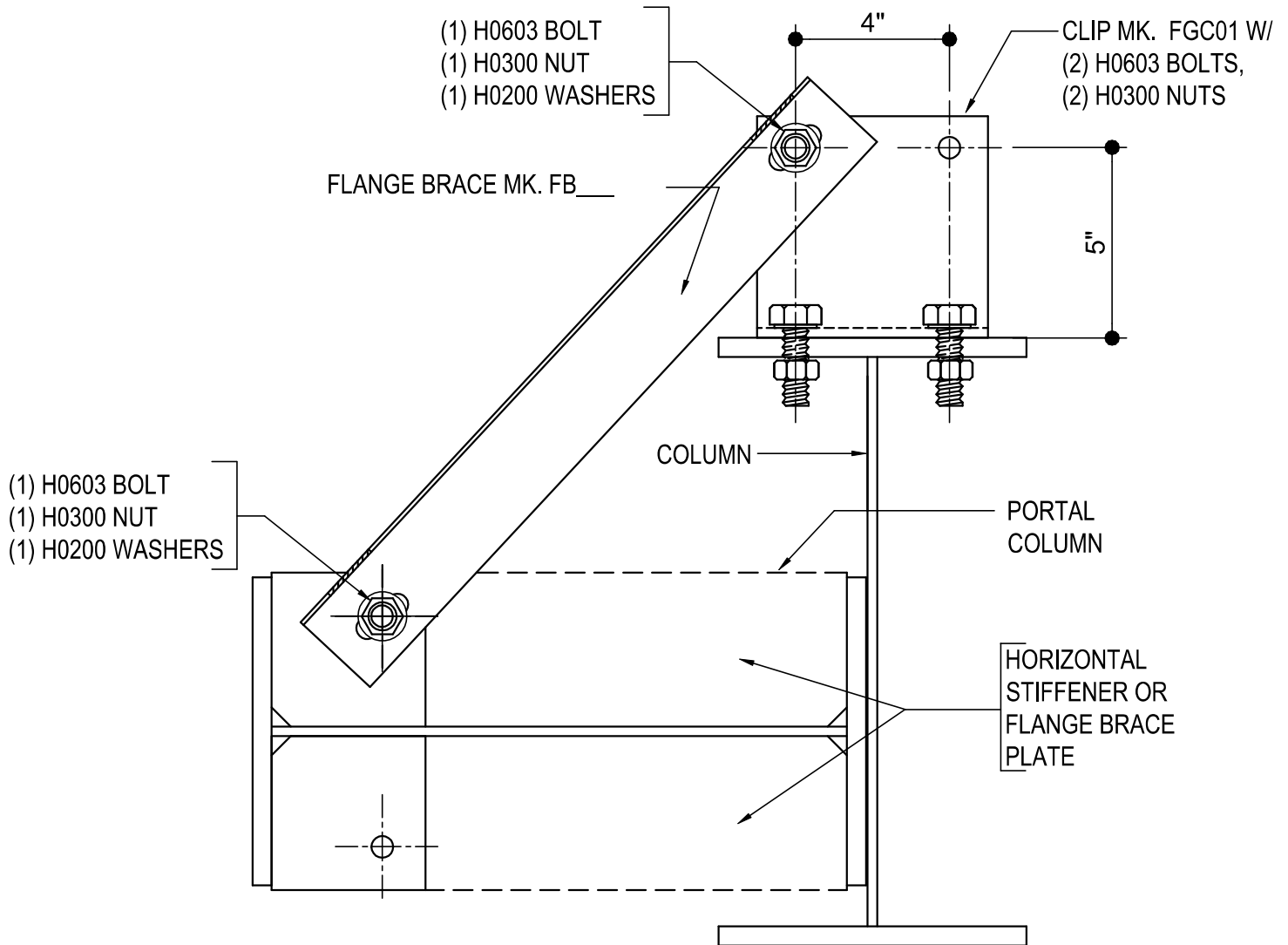

ALT FLANGE BRACE AT COLUMN & NESTED PORTAL COLUMN

SEE PLANS AND ELEVATIONS FOR FLANGE BRACE PART MARKS

AJ0056

Detailer Notes:

- 1) DO NOT CONNECT THE FLANGE BRACE TO THE COLUMN CAP PLATE.