

**MEZZANINE FLANGE BRACING DETAILS**

AP0005 - FLANGE BRACING AT MEZZANINE

---

AP0005 - FLANGE BRACING AT MEZZANINE

[Download the DWG file by clicking here.](#)

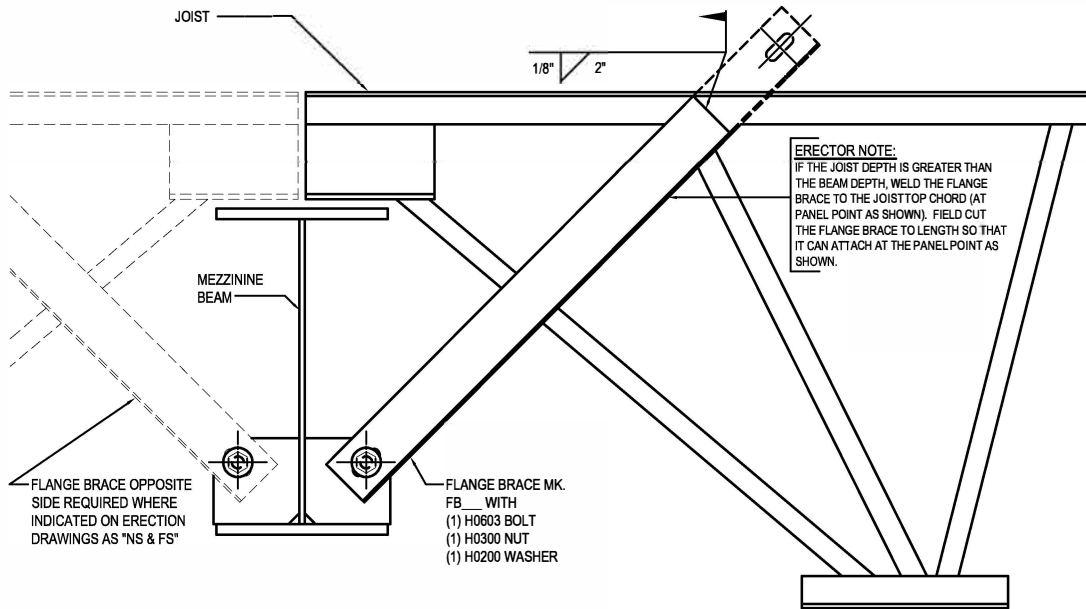

**FLANGE BRACE DETAILS IF JOIST DEPTH GREATER THAN BEAM DEPTH**

ALL FLANGE BRACE CONNECTIONS REQUIRE 1/2" x 2" A325 BOLTS UNLESS NOTED OTHERWISE  
SEE PLANS AND ELEVATIONS FOR FLANGE BRACE PART MARKS

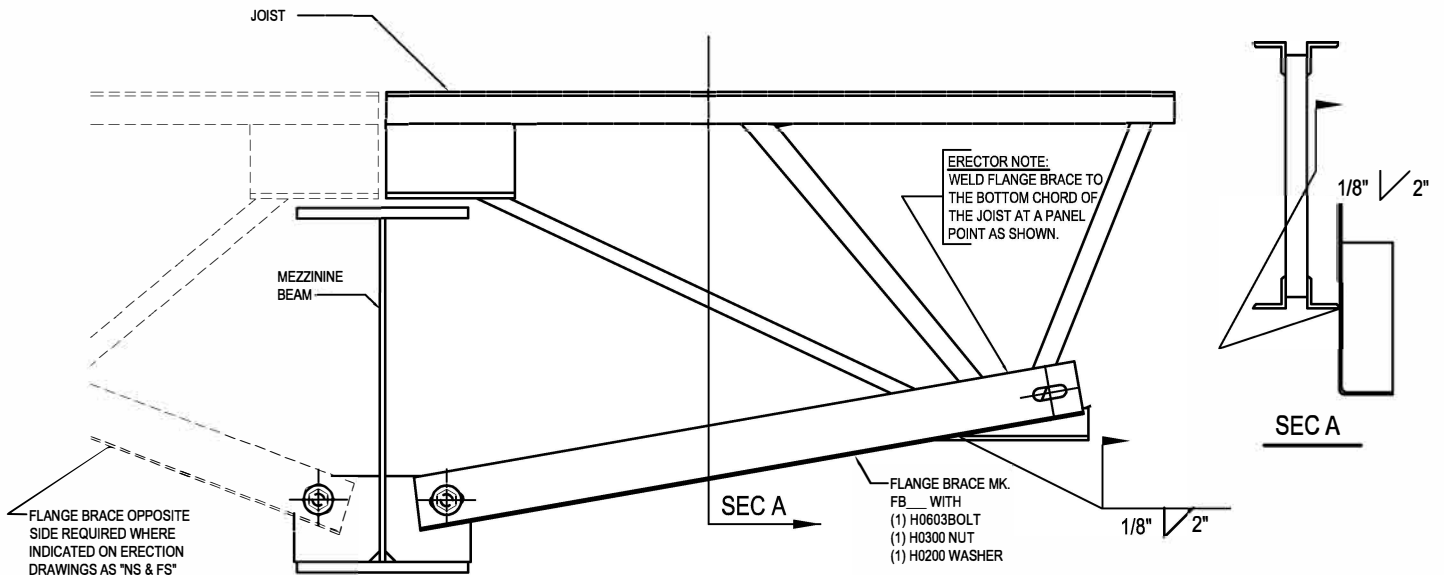

**FLANGE BRACE DETAILS IF BEAM DEPTH GREATER THAN JOIST DEPTH**

ALL FLANGE BRACE CONNECTIONS REQUIRE 1/2" x 2" A325 BOLTS UNLESS NOTED OTHERWISE  
SEE PLANS AND ELEVATIONS FOR FLANGE BRACE PART MARKS

AP0005

AP0005

**Detailer Notes:**

- 1) N/A