

HIGH EAVE DETAILS

HIGH EAVE GIRT DETAILS

- BC0051 - CEE GIRT INTERIOR AN END FRAME DETAIL
- BC0060 - GIRT @ SINGLE CEE EW RAFTER
- BC0061 - CEE GIRT TO ENDWALL RAFTER
- BC0070 - GIRT AT COLD-FORMED RAFTER DETAIL
- BC0071 - CEE GIRT AT COLD-FORMED RAFTER DETAIL
- BC0105 - GIRT AT BYPASS INTERIOR AND END FRAME DETAIL
- BC0106 - GIRT AT SIMPLE SPAN INTERIOR AND END FRAME DETAIL
- BC0115 - GIRT FLUSH OR INSET INTERIOR AND END FRAME DETAIL

HIGH EAVE STRUT DETAILS

- BC0305 - FLUSH/INSET SW GIRT DETAIL
- BC0306 - BYPASS SW GIRT DETAIL
- BC0310 - TERMINATION BYPASS SW GIRT DETAIL
- BC0315 - FLUSH/INSET WITH STRUT PLATE
- BC0316 - BYPASS SW GIRT WITH STRUT PLATE DETAIL
- BC0325 - FLUSH/INSET SW GIRT AT ENDWALL DETAIL
- BC0326 - AT ENDWALL DETAIL
- BC0327 - BYPASS SW GIRT AT ENDWALL DETAIL
- BC0328 - FLUSH/INSET SW GIRT AT ENDWALL DETAIL
- BC0345 - TO COLD-FORMED ENDWALL RAFTER DETAIL
- BC0455 - EQUAL LEG HIGH EAVE STRUT AT COLUMN DETAIL
- BC0500 - HORIZONTAL HIGH EAVE STRUT
- BC0510 - HIGH EAVE STRUT INTERIOR AND END FRAME DETAIL (HORIZONTAL)
- BC0511 - HIGH EAVE STRUT GIRT AT COLD-FORMED RAFTER DETAIL (HORIZONTAL)
- BC0512 - HIGH EAVE STRUT TO ENDWALL RAFTER (HORIZONTAL)

R-BOOST DETAILS

- BC2000 - HIGH EAVE MEMBER FOR R-BOOST
-

BC0051 - HIGH EAVE CEE GIRT INTERIOR AN END FRAME DETAIL

[Download the DWG file by clicking here.](#)

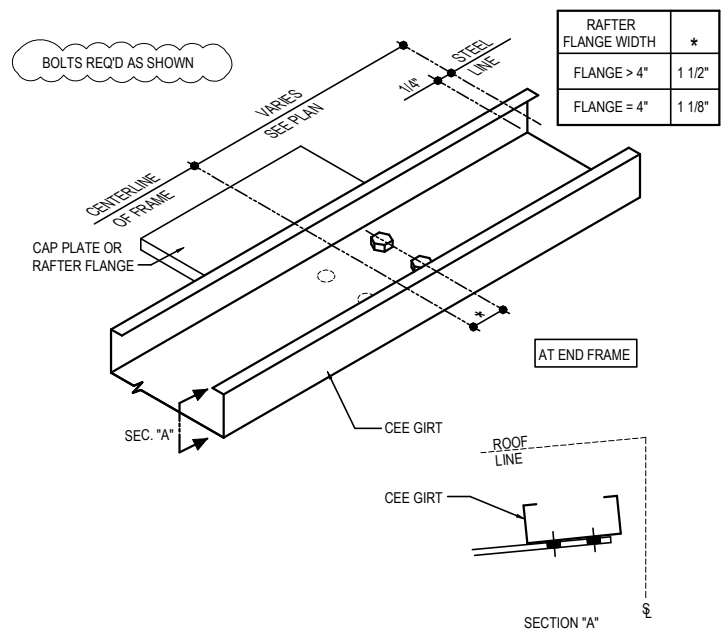
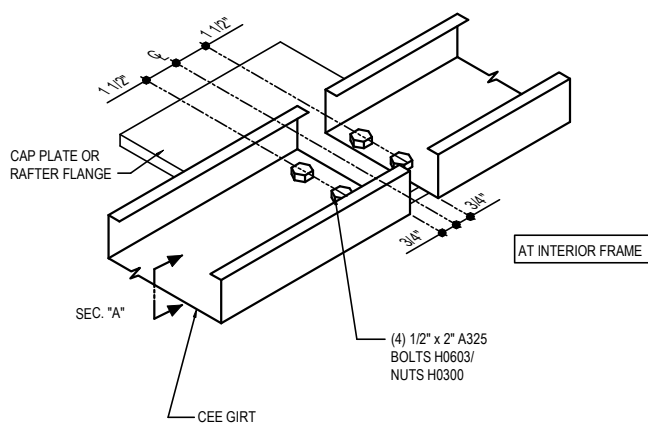

HIGH EAVE CEE GIRT INTERIOR AND END FRAME

LEAN-TO WITH OPEN COMMON WALL
SEE ERECTOR NOTE FOR TYP. WASHER REQUIREMENTS

BC0051

Detailer Notes:

- 1) N/A

BC0060 - HIGH EAVE GIRT @ SINGLE CEE EW RAFTER

[Download the DWG file by clicking here.](#)

BOLTS REQ'D AS SHOWN

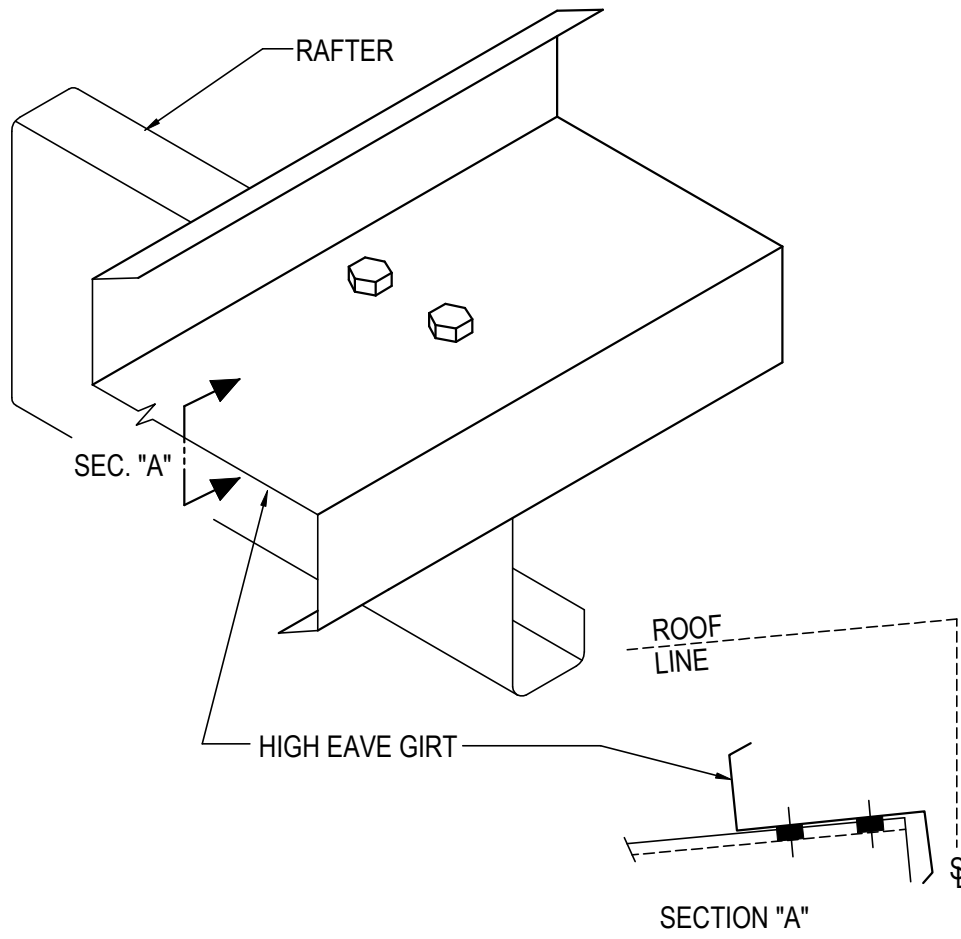

HIGH EAVE GIRT @ SINGLE CEE EW RAFTER

HIGH EAVE AT COLD-FORMED RAFTER

USE (2) 1/2" x 1 1/4" A307 BOLTS H0500/NUTS H0300

REFERENCE ERECTOR NOTE FOR TYP. WASHER REQUIREMENTS

BC0060

Detailer Notes:

1) USE THIS DETAIL WITH THE FOLLOWING LIMITATIONS:

- 8" CF RAFTERS: ROOF SLOPE \leq 2:12
- 12" CF RAFTERS: ROOF SLOPE \leq 1:12

BC0061 - CEE GIRT TO ENDWALL RAFTER

[Download the DWG file by clicking here.](#)

BOLTS REQ'D ONLY AS SHOWN,
NOT @ ALL HOLES

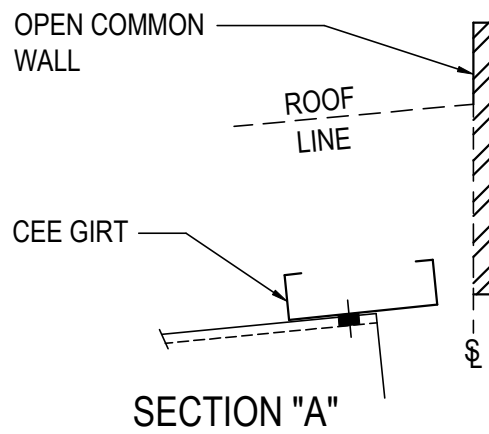
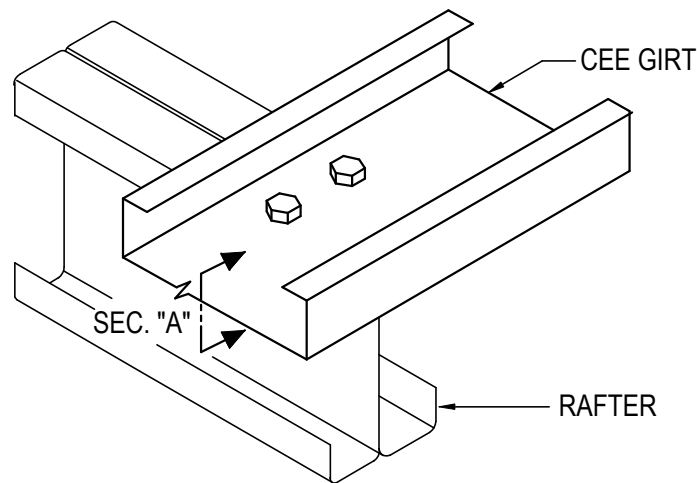

CEE GIRT TO ENDWALL RAFTER

LEAN-TO WITH OPEN COMMON WALL

HIGH EAVE CONNECTION AT COLD-FORMED RAFTER

USE (2) 1/2" X 1 1/4" A307 BOLTS H0500/NUTS H0400 U.N.O.

SEE ERECTOR NOTE FOR TYP. WASHER REQUIREMENTS

BC0061

Detailer Notes:

- 1) THIS DETAIL IS INTENDED FOR NO WALL PANEL CONDITIONS ONLY. HIGH EAVE CEE GIRT USED AS INSULATION TIE-OFF ONLY AT OPEN COMMON WALL.

BC0070 - HIGH EAVE GIRT AT COLD-FORMED RAFTER DETAIL

[Download the DWG file by clicking here.](#)

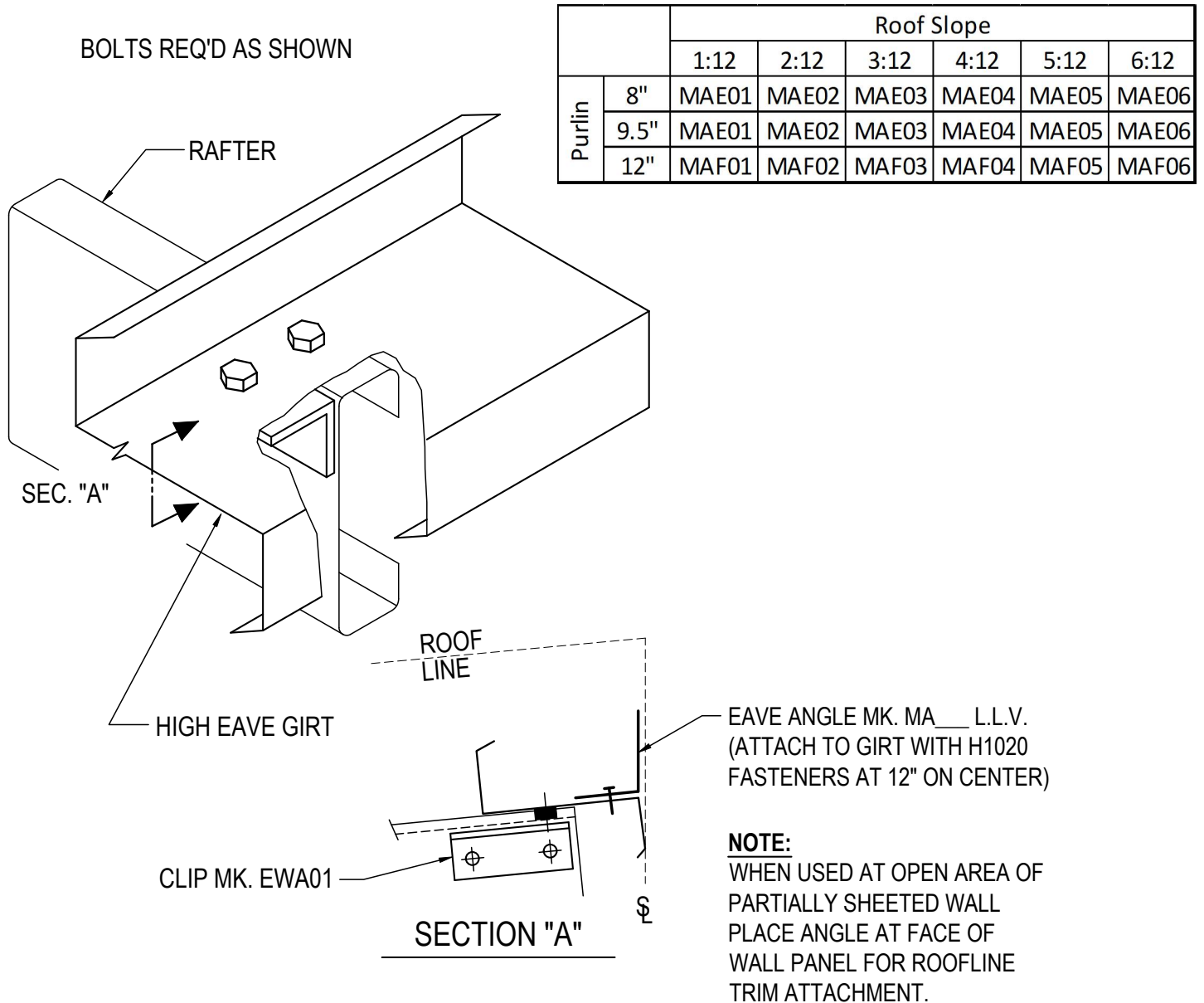

HIGH EAVE GIRT

HIGH EAVE AT COLD-FORMED RAFTER
USE (4) 1/2" x 1 1/4" A307 BOLTS H0500/NUTS H0400
REFERENCE ERECTOR NOTE FOR TYP. WASHER REQUIREMENTS

BC0070

Detailer Notes:

- 1) N/A

BC0071 - HIGH EAVE CEE GIRT AT COLD-FORMED RAFTER DETAIL

[Download the DWG file by clicking here.](#)

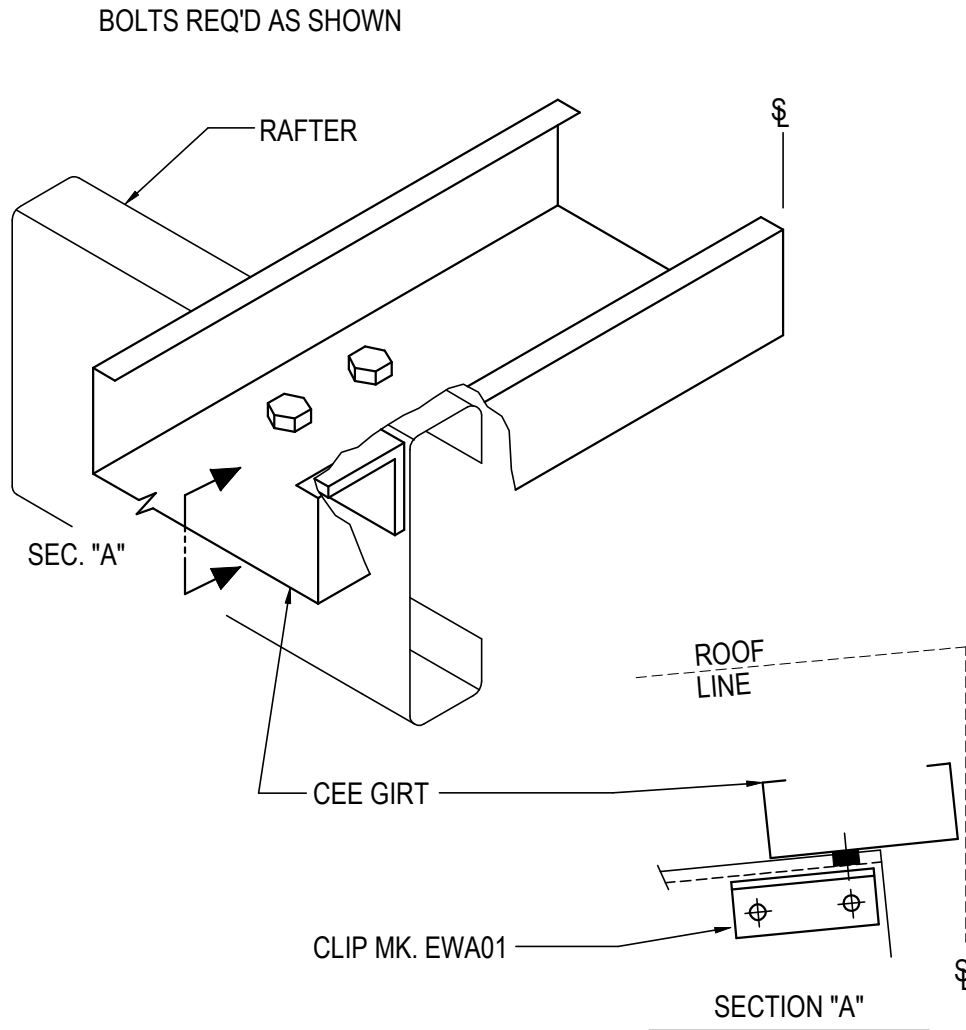

CEE GIRT TO COLD FORMED RAFTER

HIGH EAVE AT COLD-FORMED RAFTER >4:12 ROOF SLOPE
 USE (4) 1/2" x 1 1/4" A307 BOLTS H0500/NUTS H0400
 REFERENCE ERECTOR NOTE FOR TYP. WASHER REQUIREMENTS

BC0071

Detailer Notes:

- 1) SEE ROOF SHEETING DETAILS TO DETERMINE IF MAF___, MAR___, MAL___ OR MAJ___ ANGLE IS REQUIRED.

BC0105 - HIGH EAVE GIRT AT BYPASS INTERIOR AND END FRAME DETAIL

[Download the DWG file by clicking here.](#)

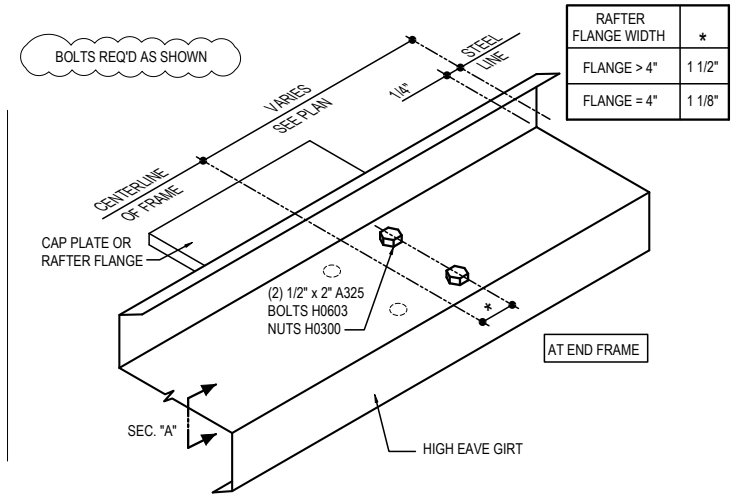
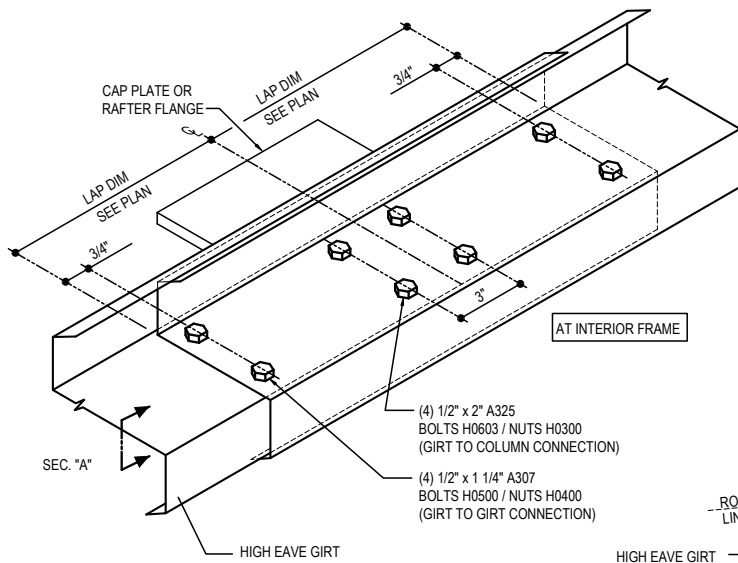

RAFTER FLANGE WIDTH	*
FLANGE > 4"	1 1/2"
FLANGE = 4"	1 1/8"

HIGH EAVE GIRT DETAIL

BYPASS INTERIOR & END FRAME
BYPASS @ ALL ROOF SLOPES
REF. ERECTOR NOTE FOR TYP. WASHER REQUIREMENTS

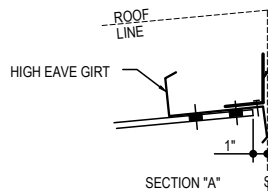

EAVE ANGLE MK. MA L.L.V.
(ATTACH TO GIRTS WITH H1020 FASTENERS AT 12" ON CENTER)

Purlin	Roof Slope					
	1:12	2:12	3:12	4:12	5:12	6:12
8"	MAE01	MAE02	MAE03	MAE04	MAE05	MAE06
9.5"	MAE01	MAE02	MAE03	MAE04	MAE05	MAE06
12"	MAF01	MAF02	MAF03	MAF04	MAF05	MAF06

NOTE:
WHEN USED AT OPEN AREA OF PARTIALLY SHEETED WALL PLACE ANGLE AT FACE OF WALL PANEL FOR ROOFLINE TRIM ATTACHMENT.

BC0105

Detailer Notes:

- 1) N/A

BC0106 - HIGH EAVE GIRT AT SIMPLE SPAN INTERIOR AND END FRAME DETAIL

[Download the DWG file by clicking here.](#)

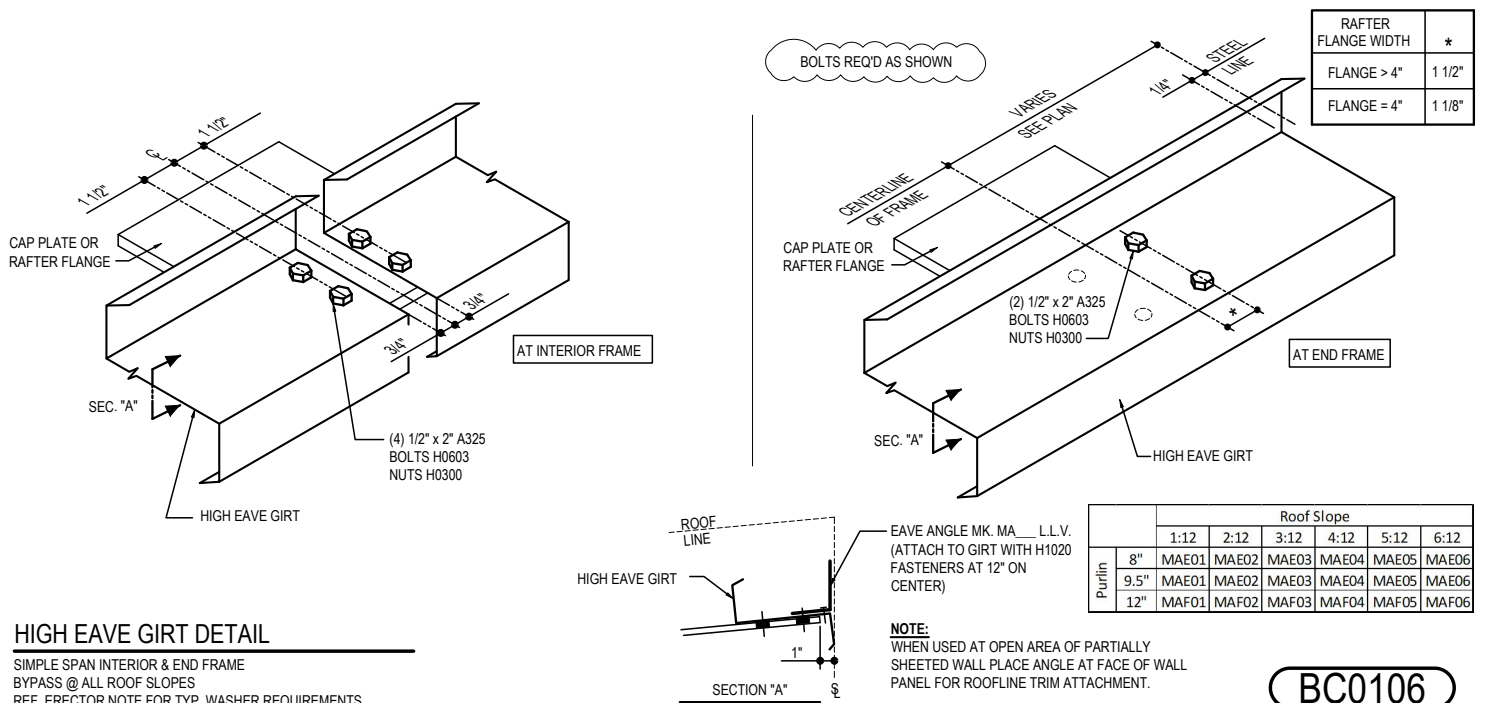

Detailer Notes:

- 1) N/A

BC0115 - HIGH EAVE GIRT FLUSH OR INSET INTERIOR AND END FRAME DETAIL

[Download the DWG file by clicking here.](#)

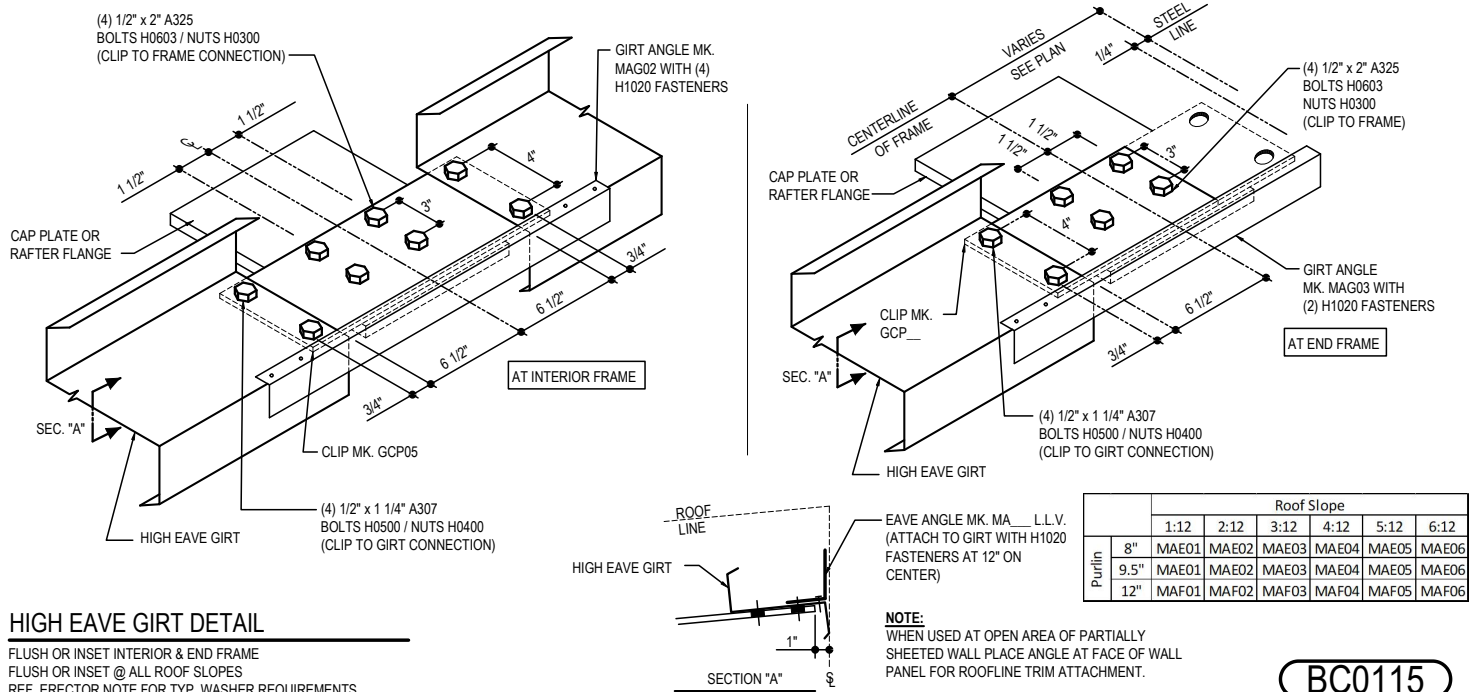

BC0115

HIGH EAVE GIRT DETAIL
FLUSH OR INSET INTERIOR & END FRAME
FLUSH OR INSET @ ALL ROOF SLOPES
REF. ERECTOR NOTE FOR TYP. WASHER REQUIREMENTS

Detailer Notes:

- 1) N/A

BC0305 - HIGH EAVE STRUT FLUSH/INSET SW GIRT DETAIL

[Download the DWG file by clicking here.](#)

H1020 AT EACH END
AT IMP WALL, USE H1220

ANGLE MK. MAH__

SEC. A

BOLTS REQ'D AS SHOWN

PART	ROOF SLOPE
MAH11	1:12
MAH12	2:12
MAH13	3:12
MAH14	4:12

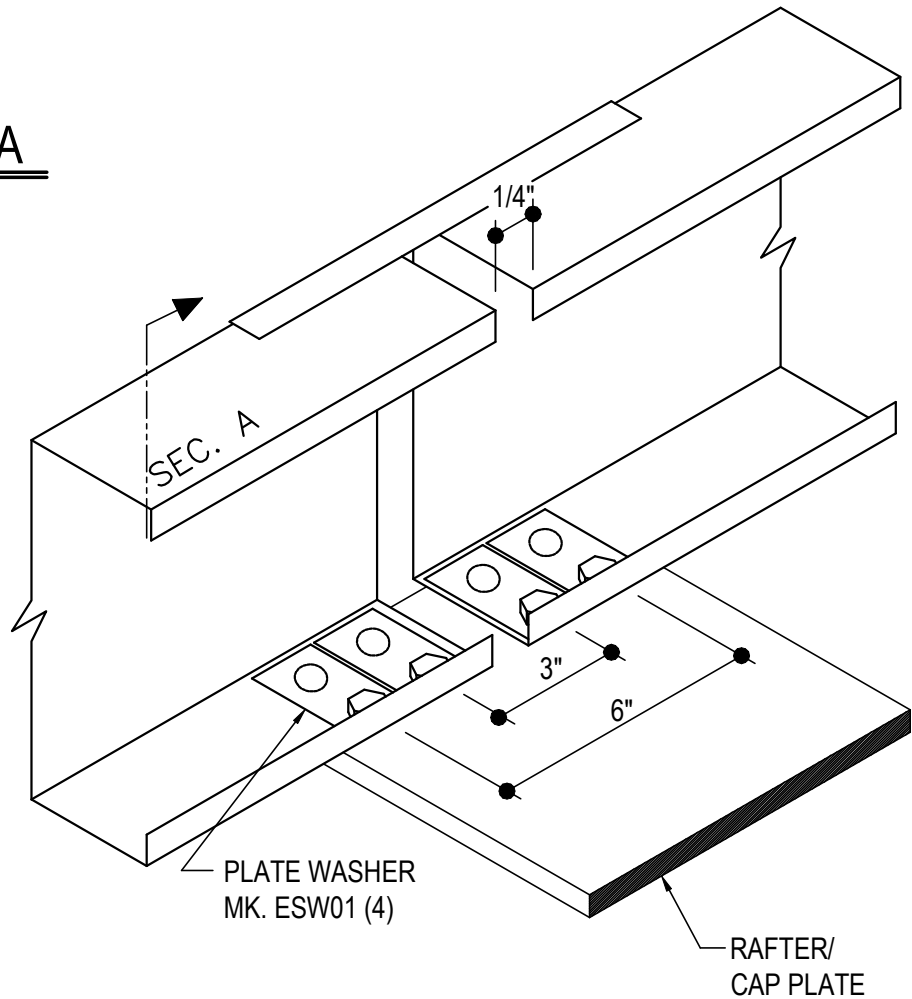

HIGH EAVE STRUT

HIGH EAVE FLUSH/INSET SW GIRT CONDITION
USE (4) 1/2" X 2" A325 BOLT H0603/NUT H0300 U.N.O.

BC0305

Detailer Notes:

- 1) 8" MIN. CAP PLATE

BC0306 - HIGH EAVE STRUT BYPASS SW GIRT DETAIL

[Download the DWG file by clicking here.](#)

H1020 AT EACH END
AT IMP WALL, USE H1220

ANGLE MK. MAH_

BOLTS REQ'D AS SHOWN

SEC. A

PART	ROOF SLOPE
MAH11	1:12
MAH12	2:12
MAH13	3:12
MAH14	4:12

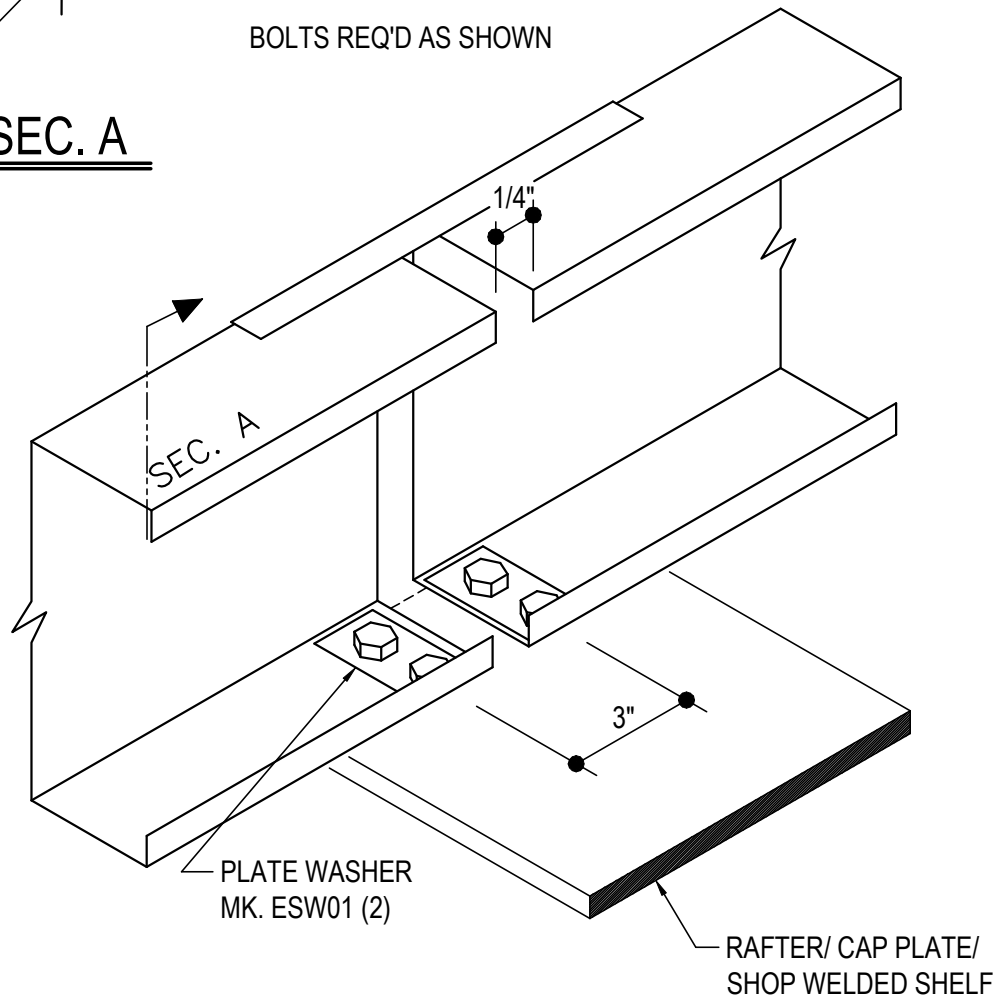

HIGH EAVE STRUT

HIGH EAVE BYPASS SW GIRT CONDITION
USE (4) 1/2" X 2" A325 BOLT H0603/NUT H0300 U.N.O.

BC0306

Detailer Notes:

- 1) CAP PLATE WIDTH BE AT LEAST 5"

BC0310 - HIGH EAVE STRUT TERMINATION BYPASS SW GIRT DETAIL

[Download the DWG file by clicking here.](#)

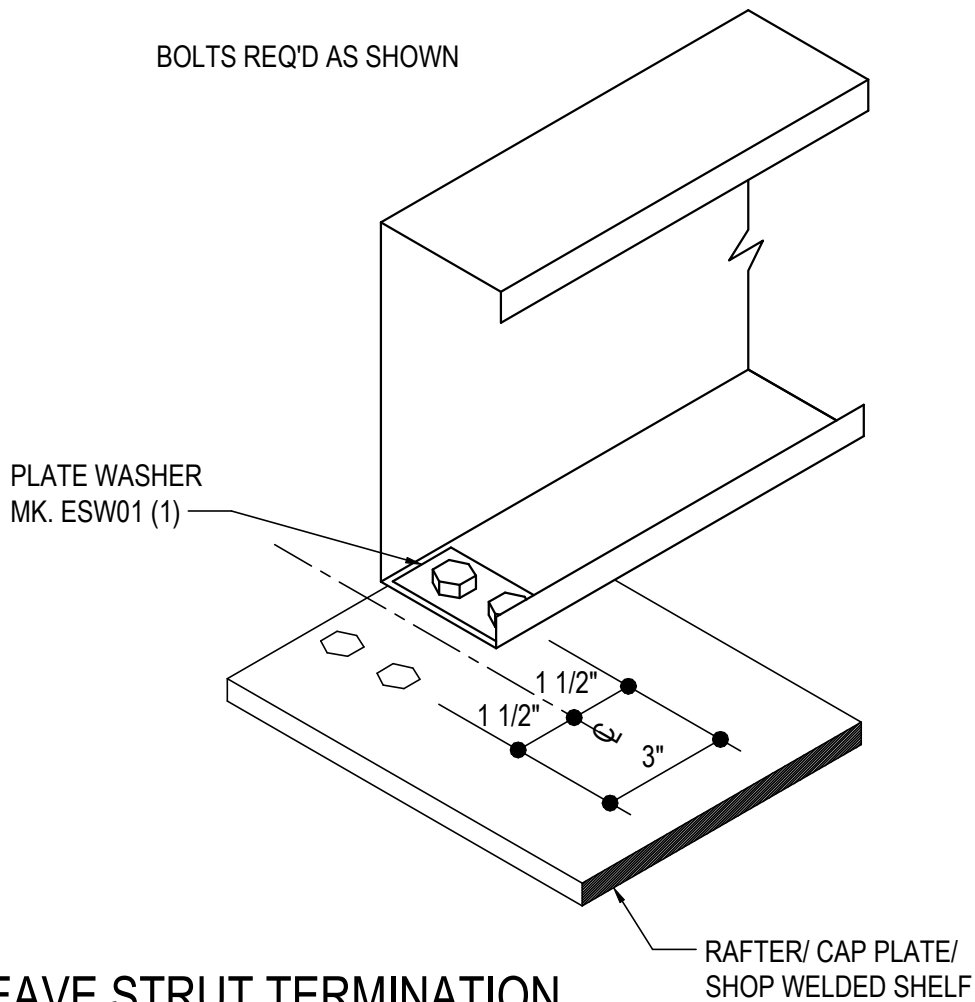

HIGH EAVE STRUT TERMINATION

HIGH EAVE BYPASS SW GIRT CONDITION
USE (2) 1/2" X 2" A325 BOLT H0603/NUT H0300 U.N.O.

BC0310

Detailer Notes:

- 1) CAP PLATE WIDTH BE AT LEAST 5"

BC0315 - HIGH EAVE STRUT FLUSH/INSET WITH STRUT PLATE

[Download the DWG file by clicking here.](#)

H1020 AT EACH END
AT IMP WALL, USE H1220

ANGLE MK. MAH_

BOLTS REQ'D AS SHOWN

SEC. A

PART	ROOF SLOPE
MAH11	1:12
MAH12	2:12
MAH13	3:12
MAH14	4:12

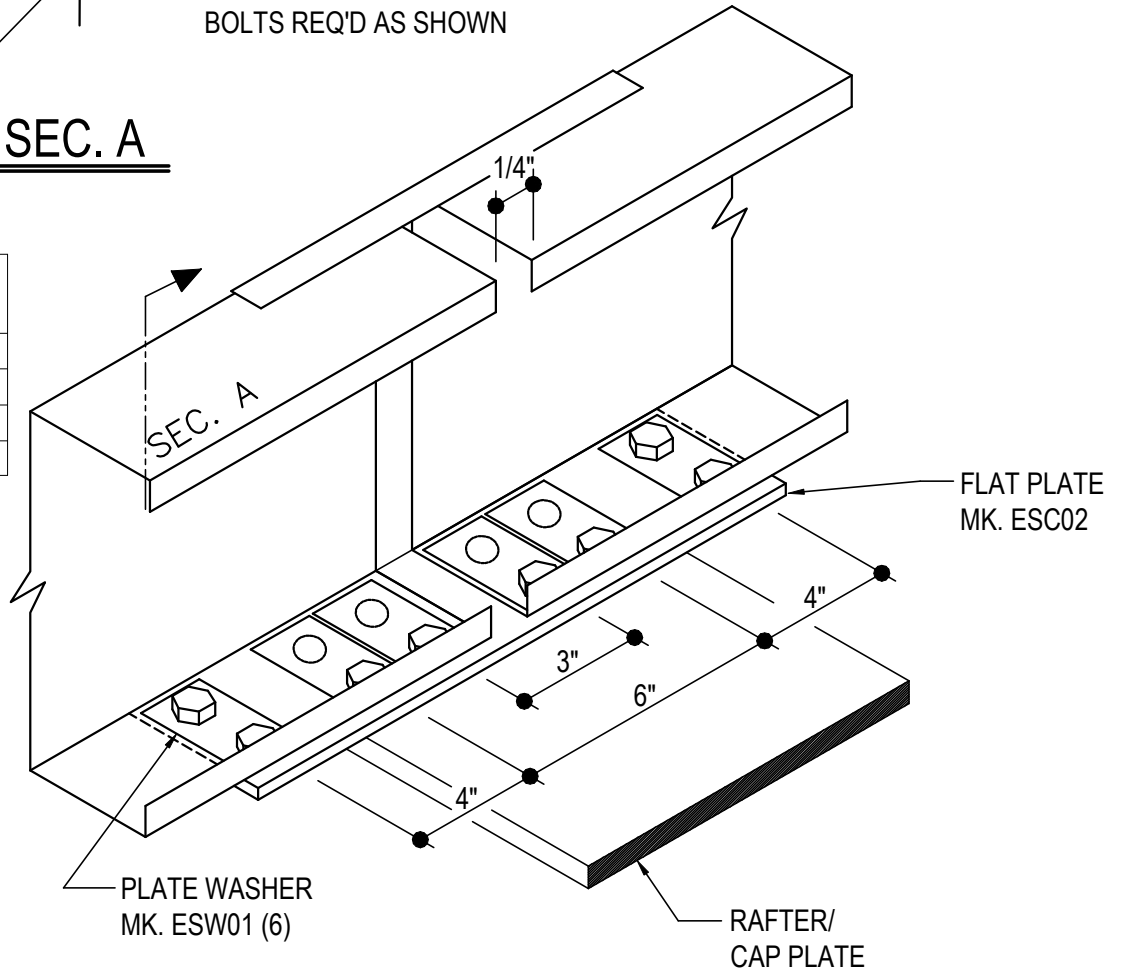

HIGH EAVE STRUT

FLUSH/INSET WITH STRUT PLATE

NOTE: USE (8) 1/2" x 2" A325 BOLTS H0603/NUTS H0300

BC0315

Detailer Notes:

- 1) 8" MIN. CAP PLATE

BC0316 - HIGH EAVE STRUT BYPASS SW GIRT WITH STRUT PLATE DETAIL

[Download the DWG file by clicking here.](#)

H1020 AT EACH END
AT IMP WALL, USE H1220

ANGLE MK. MAH_

BOLTS REQ'D AS SHOWN

SEC. A

PART	ROOF SLOPE
MAH11	1:12
MAH12	2:12
MAH13	3:12
MAH14	4:12

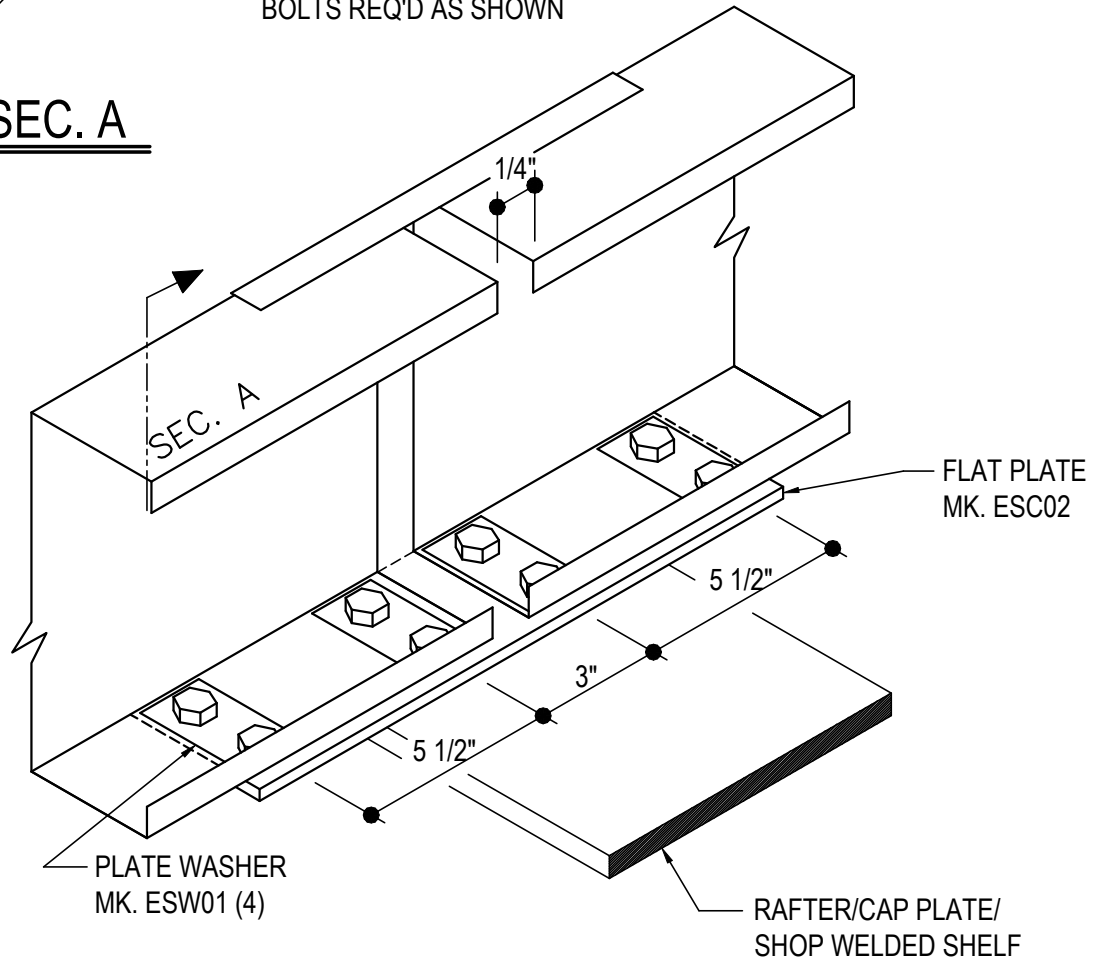

HIGH EAVE STRUT

HIGH EAVE BYPASS SW GIRT CONDITION WITH STRUT PLATE
USE (8) 1/2" X 2" A325 BOLT H0603/NUT H0300 U.N.O.

BC0316

Detailer Notes:

- 1) CAP PLATE WIDTH BE AT LEAST 5"

BC0325 - HIGH EAVE STRUT FLUSH/INSET SW GIRT AT RIGID FRAME ENDWALL DETAIL

[Download the DWG file by clicking here.](#)

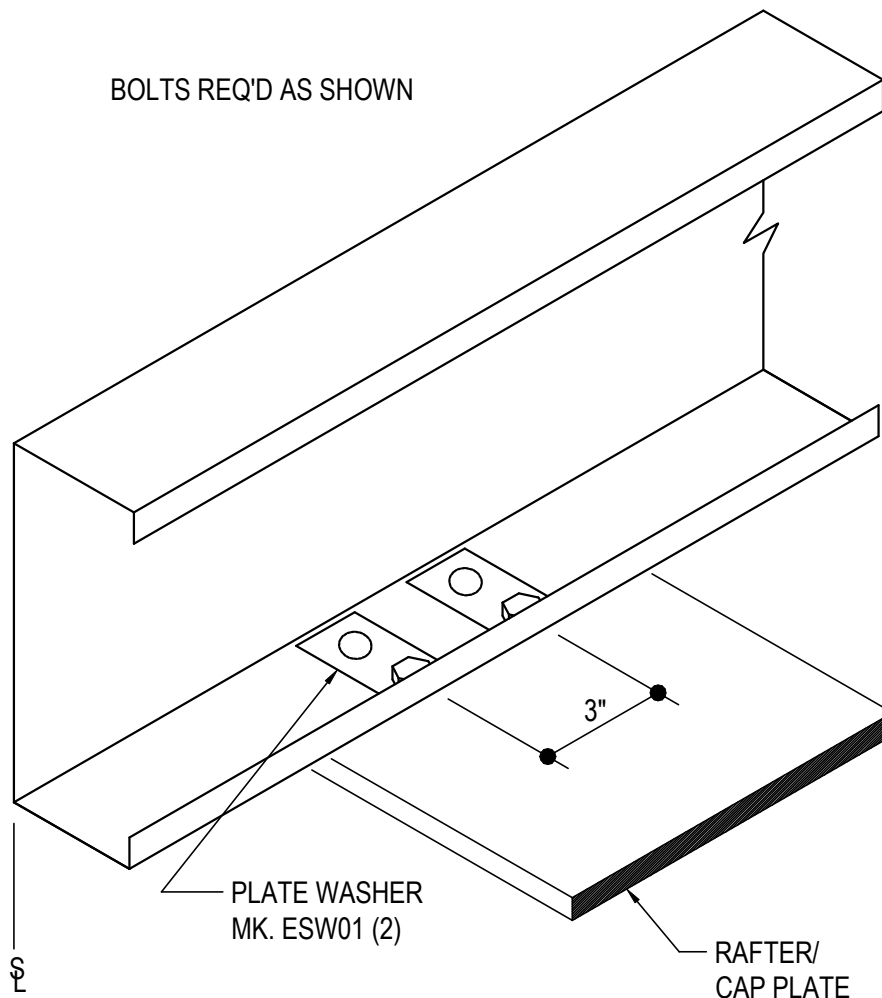

HIGH EAVE STRUT AT ENDWALL

HIGH EAVE - FLUSH, INSET SW GIRT CONDITION AT RIGID FRAME ENDWALL
USE (2) 1/2" X 2" A325 BOLT H0603/NUT H0300 U.N.O.

BC0325

Detailer Notes:

- 1) CAP PLATE WIDTH BE AT LEAST 5"

BC0326 - HIGH EAVE STRUT AT ENDWALL DETAIL

[Download the DWG file by clicking here.](#)

BOLTS REQ'D ONLY AS SHOWN

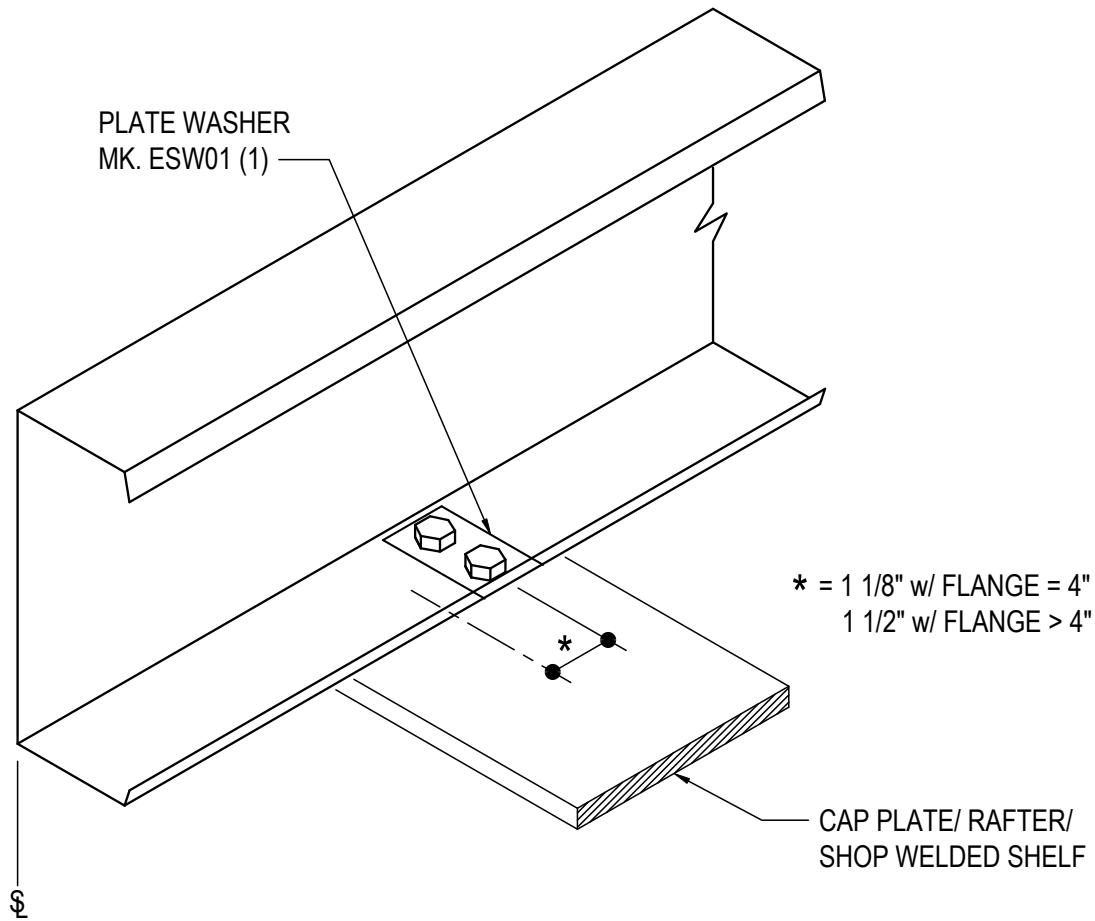

HIGH EAVE STRUT AT ENDWALL

USE (2) 1/2" x 2" A325 BOLT H0603/NUT H0300

BC0326

Detailer Notes:

1) N/A

BC0327 - HIGH EAVE STRUT BYPASS SW GIRT AT ENDWALL DETAIL

[Download the DWG file by clicking here.](#)

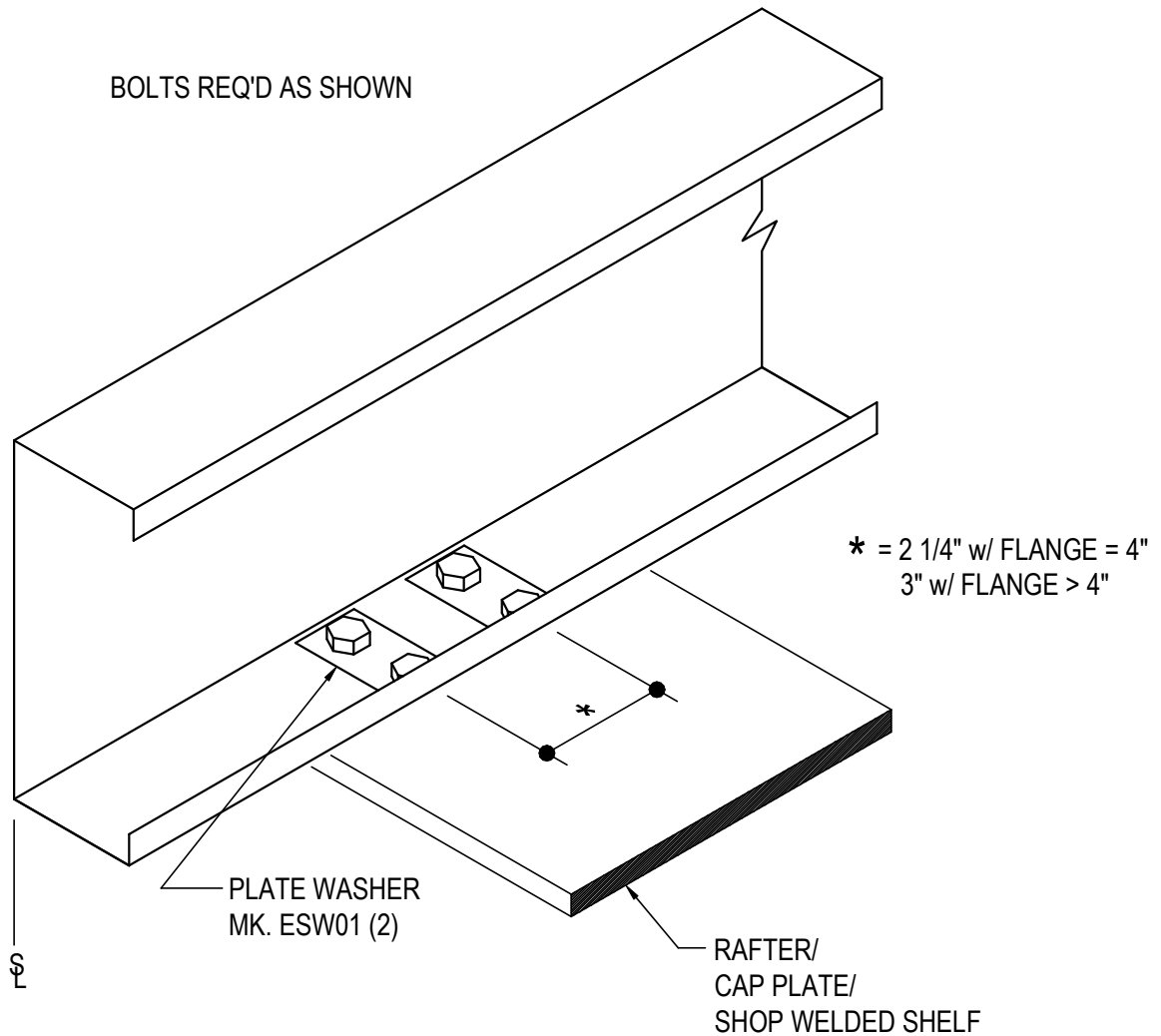

HIGH EAVE STRUT AT ENDWALL

HIGH EAVE - BYPASS SW GIRT CONDITION
USE (4) 1/2" X 2" A325 BOLT H0603/NUT H0300 U.N.O.

BC0327

Detailer Notes:

- 1) N/A

BC0328 - HIGH EAVE STRUT FLUSH/INSET SW GIRT AT ENDWALL DETAIL

[Download the DWG file by clicking here.](#)

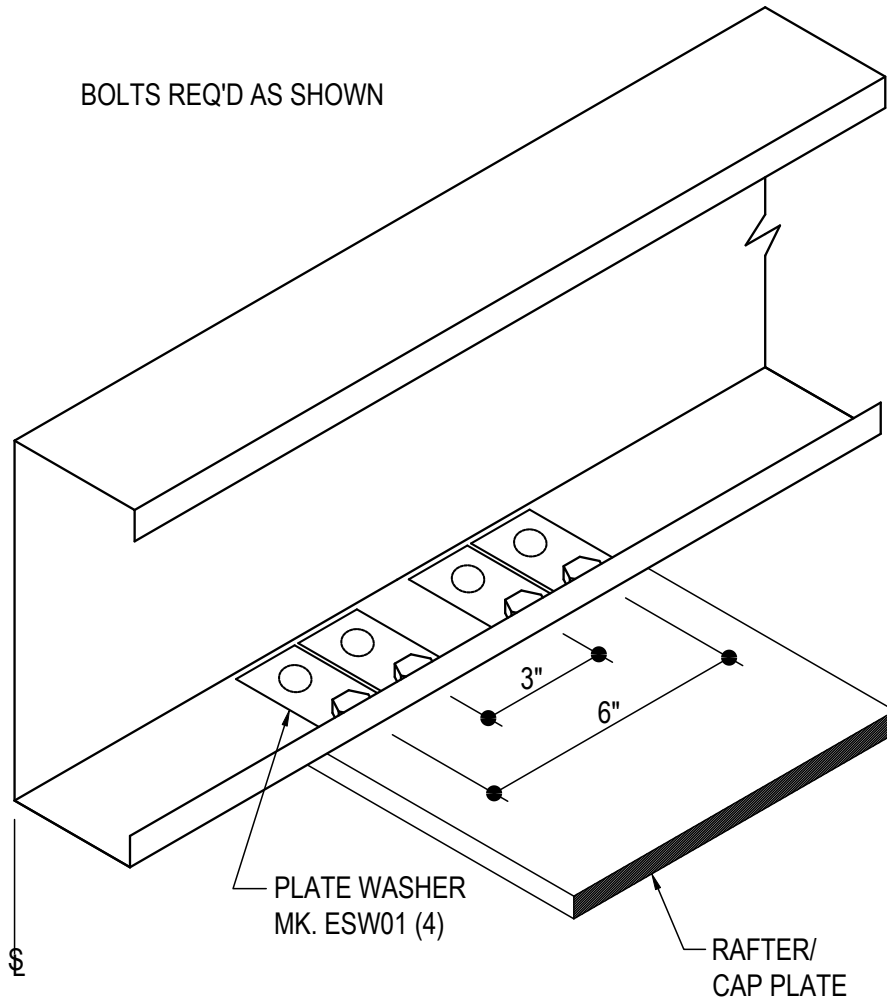

HIGH EAVE STRUT AT ENDWALL

HIGH EAVE FLUSH/INSET SW GIRT CONDITION
USE (4) 1/2" X 2" A325 BOLT H0603/NUT H0300 U.N.O.

BC0328

Detailer Notes:

- 1) MIN. 8" FLANGE CAP PLATE

BC0345 - HIGH EAVE STRUT TO COLD-FORMED ENDWALL RAFTER DETAIL

[Download the DWG file by clicking here.](#)

BOLTS REQ'D ONLY AS SHOWN,
NOT @ ALL HOLES.

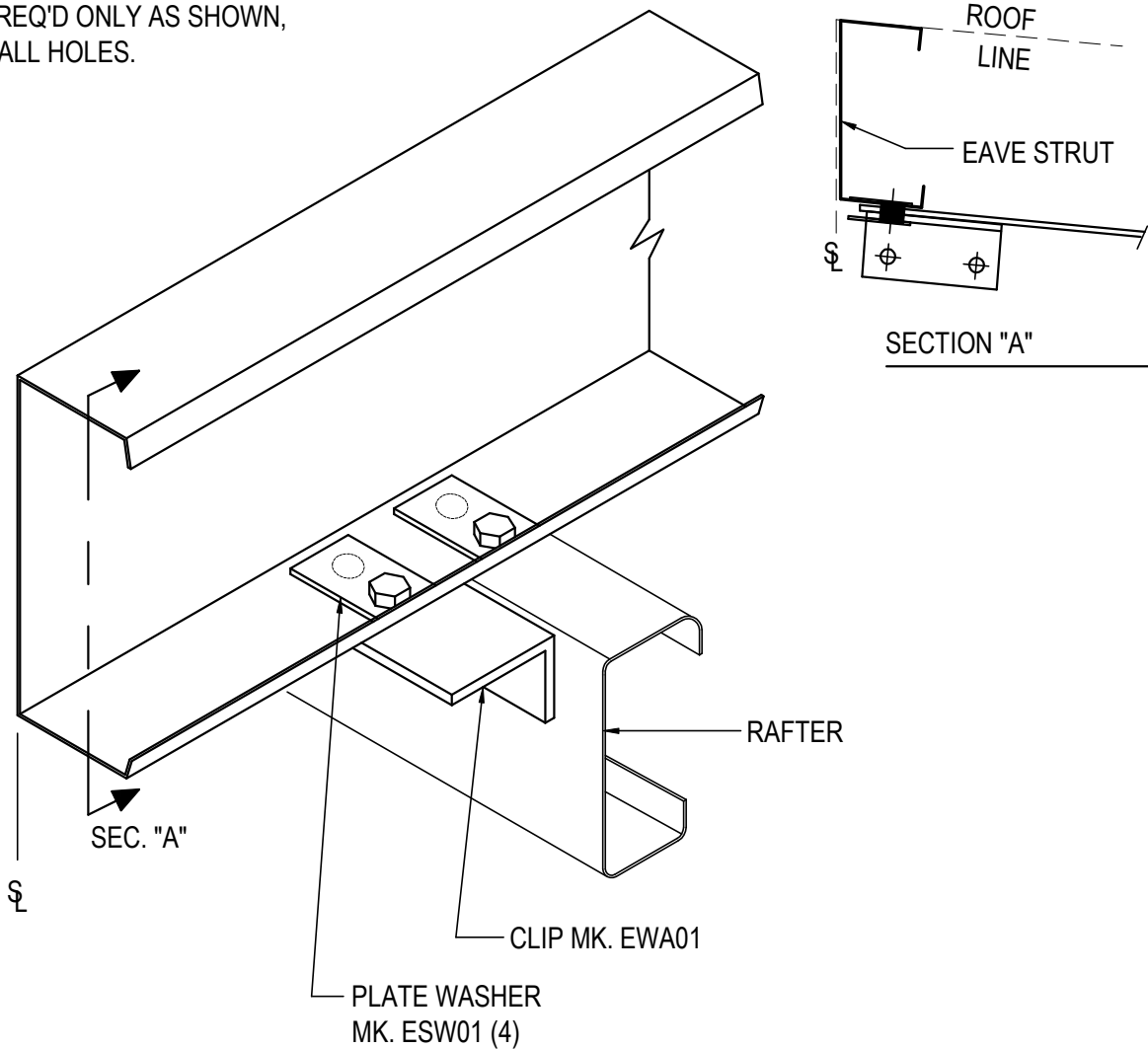

HIGH EAVE STRUT TO ENDWALL RAFTER

HIGH EAVE COLD-FORMED EW CONDITION
USE (4) 1/2" X 2" A325 BOLT H0603/NUT H0300
SEE ERECTOR NOTE FOR TYP. WASHER REQUIREMENTS

BC0345

Detailer Notes:

- 1) DETAIL NOT APPLICABLE ON ROOF SLOPES $\geq 2:12$

BC0455 - EQUAL LEG HIGH EAVE STRUT AT COLUMN DETAIL

[Download the DWG file by clicking here.](#)

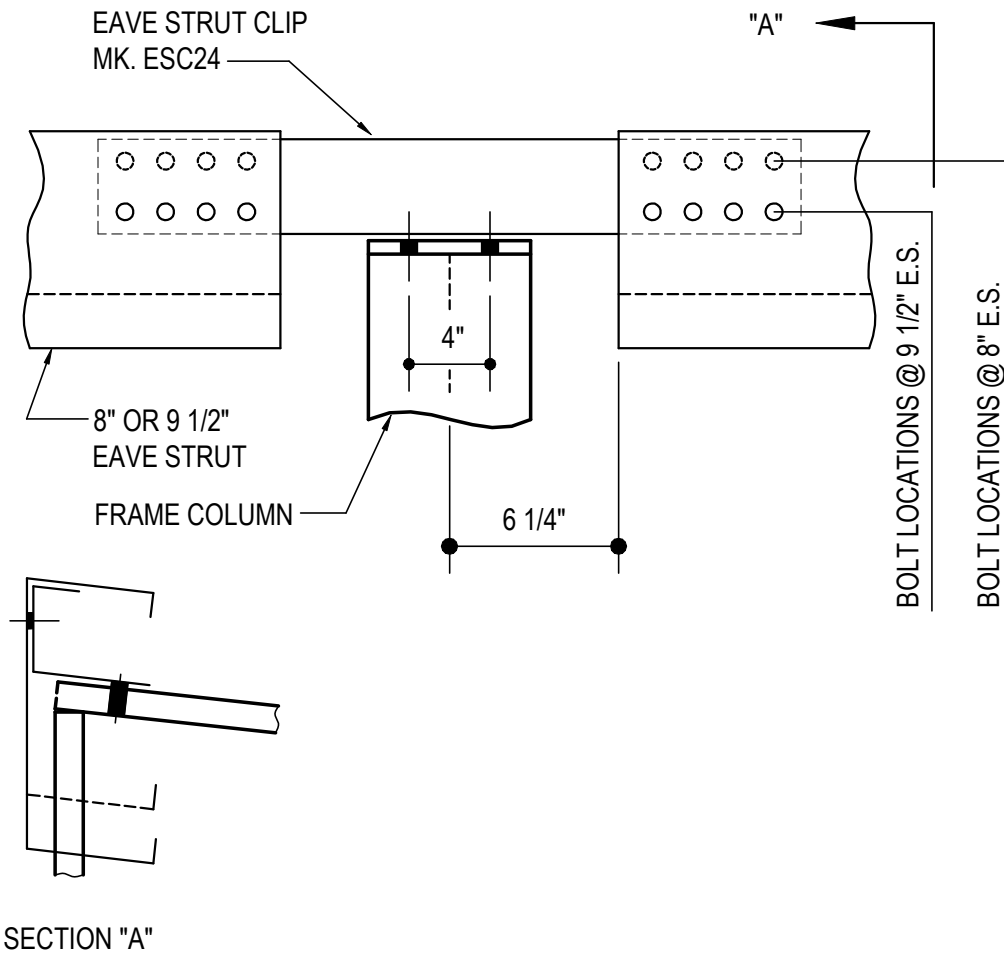

EQ LEG HIGH EAVE STRUT AT COL

USE (10) 1/2" X 2" A325 BOLTS H0603/NUTS H0300 U.N.O.

BC0455

Detailer Notes:

- 1) N/A

BC0500 - HORIZONTAL HIGH EAVE STRUT

[Download the DWG file by clicking here.](#)

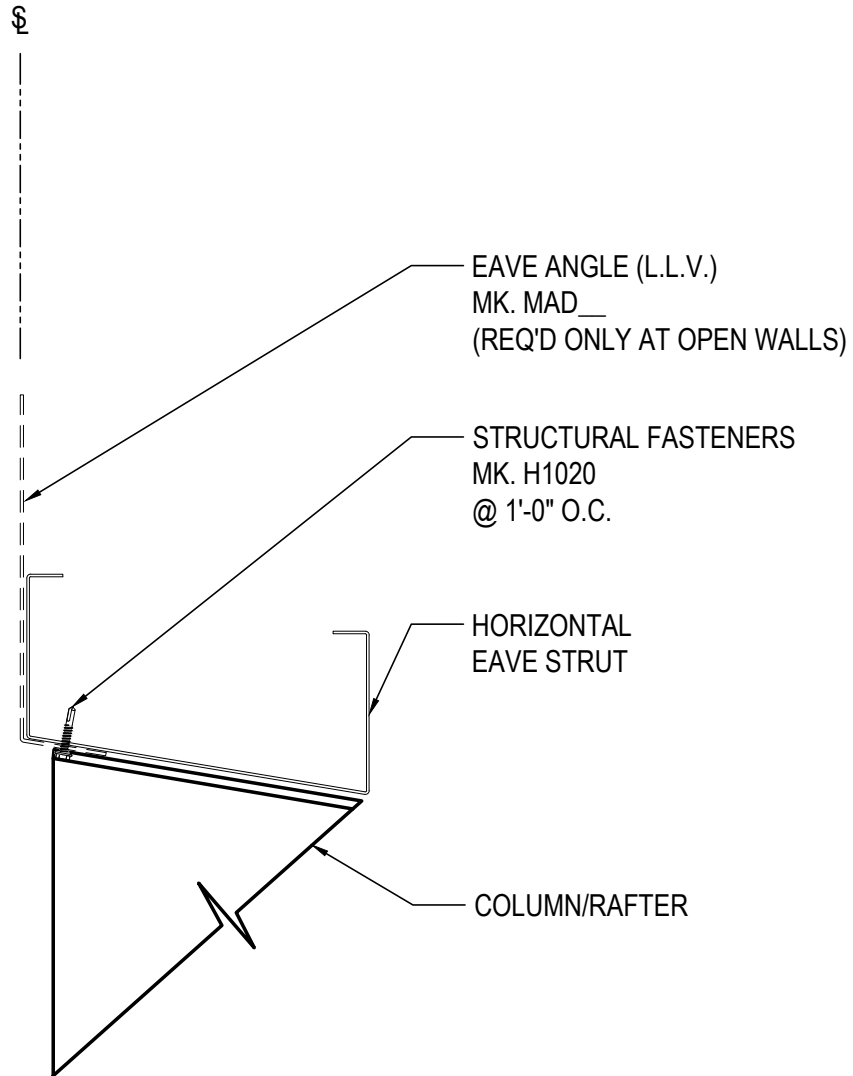

HORIZONTAL HIGH EAVE STRUT

BC0500

Detailer Notes:

- 1) DETAIL IS ONLY REQUIRED FOR STANDING SEAM ROOFS THAT UTILIZE SHORT PANEL CLIPS.

BC0510 - HIGH EAVE STRUT INTERIOR AND END FRAME DETAIL (HORIZONTAL)

[Download the DWG file by clicking here.](#)

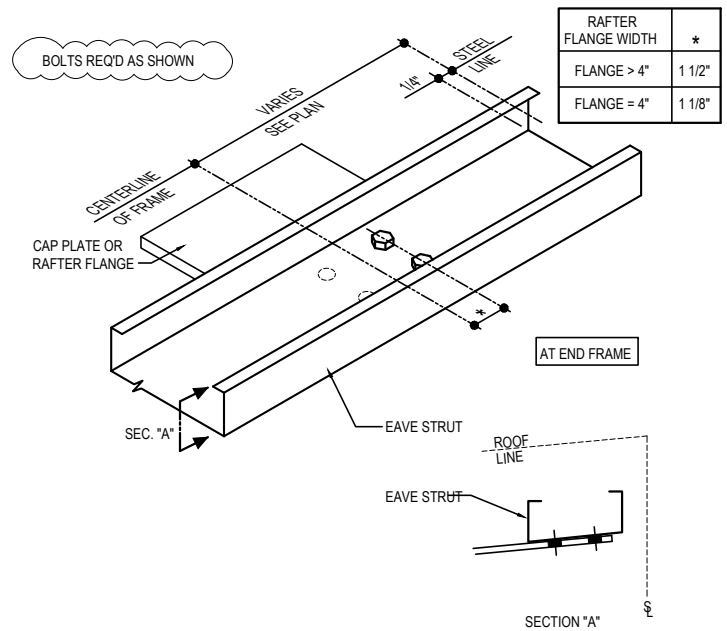
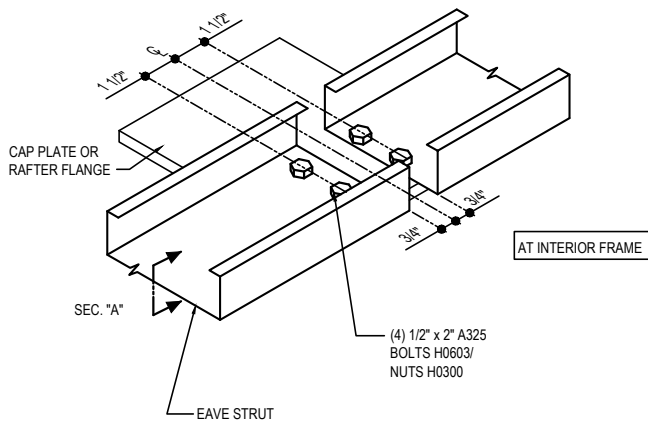

RAFTER FLANGE WIDTH	*
FLANGE > 4"	1 1/2"
FLANGE = 4"	1 1/8"

HIGH EAVE STRUT INTERIOR AND END FRAME (HORIZONTAL)

SEE ERECTOR NOTE FOR TYP. WASHER REQUIREMENTS

BC0510

Detailer Notes:

- 1) N/A

BC0511 - HIGH EAVE STRUT AT COLD-FORMED RAFTER DETAIL (HORIZONTAL)

[Download the DWG file by clicking here.](#)

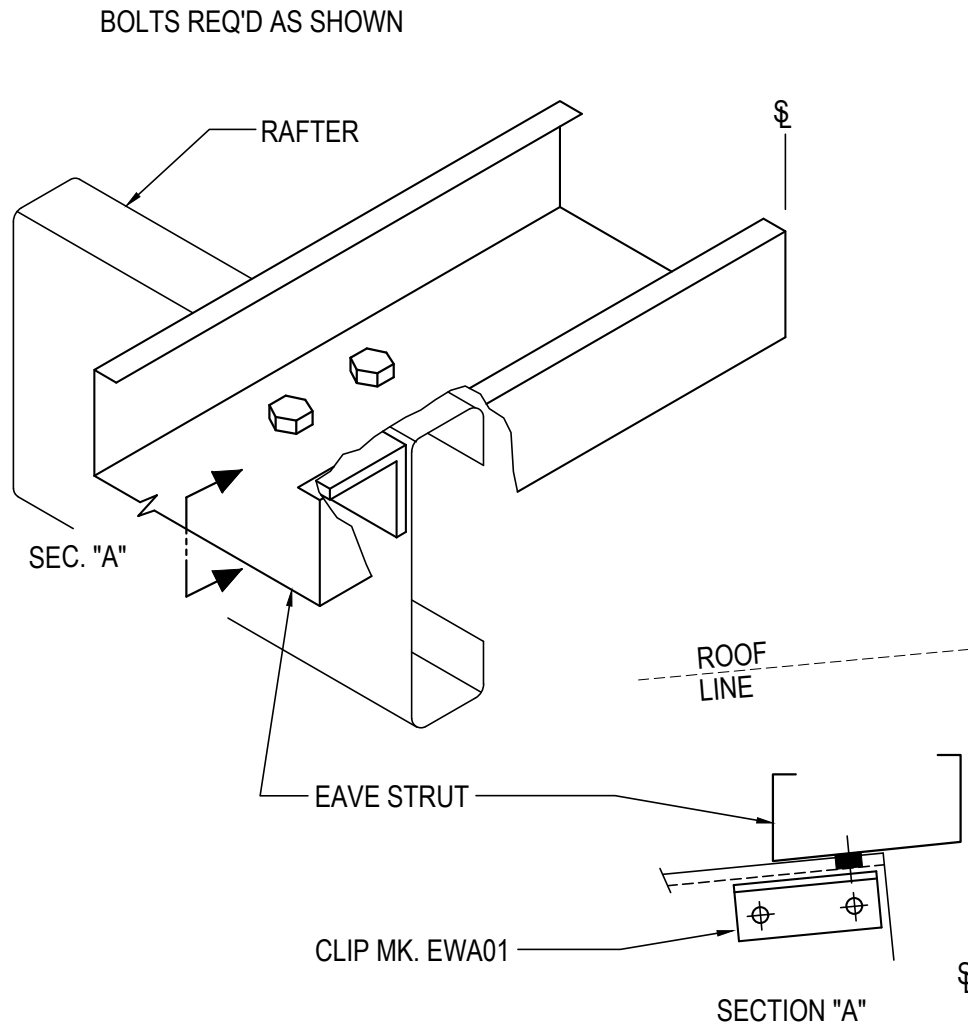

HIGH EAVE STRUT TO COLD FORMED RAFTER (HORIZONTAL)

HIGH EAVE STRUT AT COLD-FORMED RAFTER
USE (4) 1/2" x 2" A326 BOLTS H0603/NUTS H0300
REFERENCE ERECTOR NOTE FOR TYP. WASHER REQUIREMENTS

BC0511

Detailer Notes:

- 1) SEE ROOF SHEETING DETAILS TO DETERMINE IF MAF___, MAR___, MAL___ OR MAJ___ ANGLE IS REQUIRED.

BC0512 - HIGH EAVE STRUT TO ENDWALL RAFTER (HORIZONTAL)

[Download the DWG file by clicking here.](#)

BOLTS REQ'D ONLY AS SHOWN,
NOT @ ALL HOLES

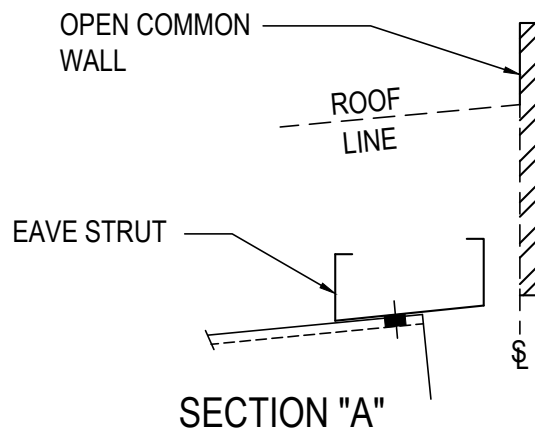
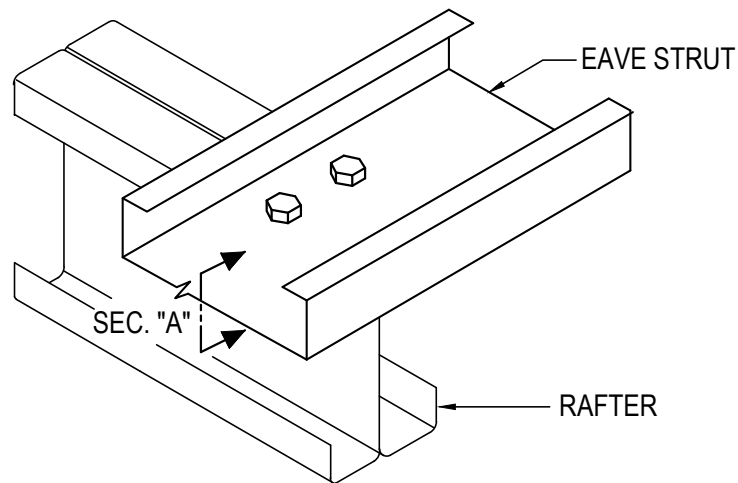

HIGH EAVE STRUT TO ENDWALL RAFTER (HORIZONTAL)

LEAN-TO WITH OPEN COMMON WALL
HIGH EAVE CONNECTION AT COLD-FORMED RAFTER
USE (2) 1/2" X 2" A325 BOLTS H0603/NUTS H0300 U.N.O.
SEE ERECTOR NOTE FOR TYP. WASHER REQUIREMENTS

BC0512

Detailer Notes:

- 1) THIS DETAIL IS INTENDED FOR NO WALL PANEL CONDITIONS ONLY. HIGH EAVE CEE GIRTS USED AS INSULATION TIE-OFF ONLY AT OPEN COMMON WALL.

BC2000 - HIGH EAVE MEMBER FOR R-Boost™

[Download the DWG file by clicking here.](#)

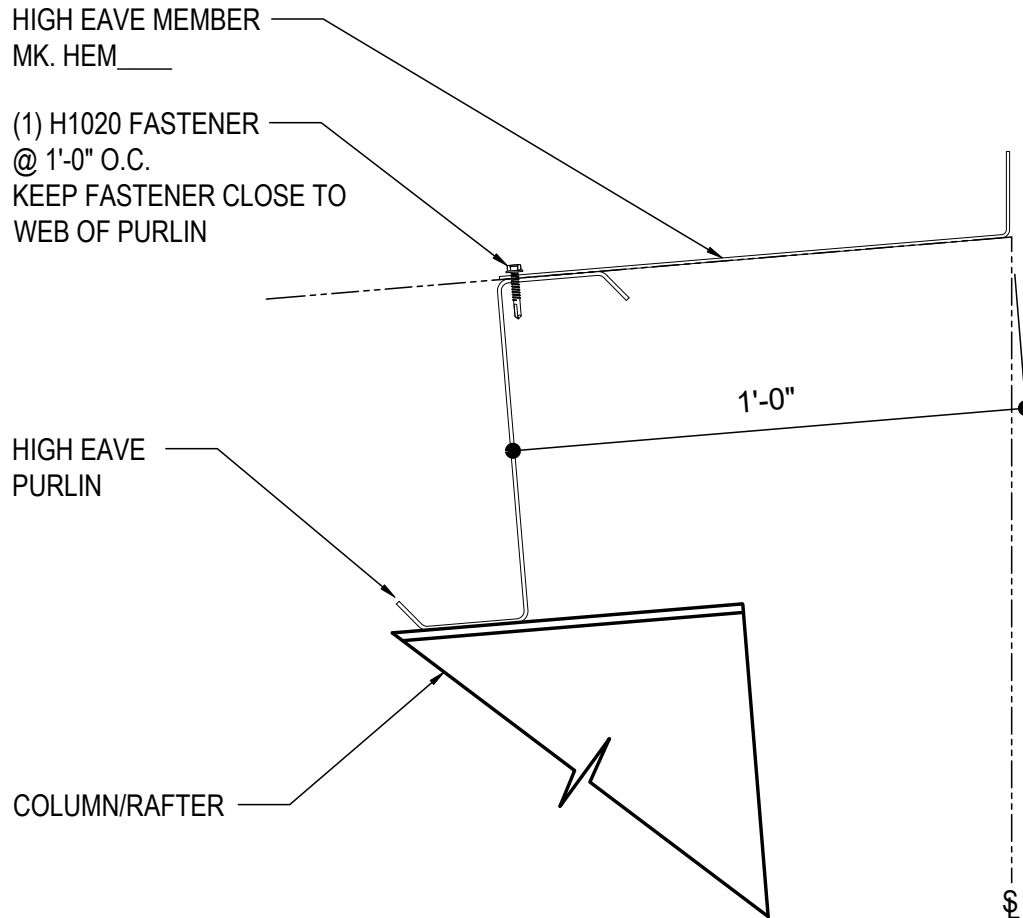

R-Boost™ HIGH EAVE MEMBER

HIGH EAVE MEMBER ATTACHMENT AT HIGH EAVE

BC2000

Detailer Notes:

1) USE ONLY WITH R-Boost™ ROOF SYSTEMS AND SINGLE SLOPE BUILDING WITH SCULPTURED HIGH EAVE CONDITION. THE HIGH EAVE MEMBER IS TO BE INSTALLED AT TIME OF PURLIN INSTALLATION.