

**RIDGE**

DG7001 - FIELD FAB PEAK BOX

DG7232 - RIDGE CAP WITH METAL PEAK BOX INSTALLATION

DG7236 - DIE-FORMED RIDGE CAP WITH METAL PEAK BOX

DG7241 - PEAK TRANSITION TO PARAPET TRIM AT VENTED RIDGE

DG7242 - VENTED RIDGE CAP WITH METAL PEAK BOX INSTALLATION (NBS)

DG7001 - FIELD FAB PEAK BOX

[Download the DWG file by clicking here.](#)

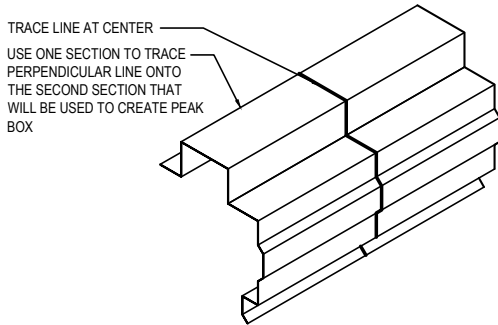

**PEAK BOX LAYOUT**  
RAKE TRIM

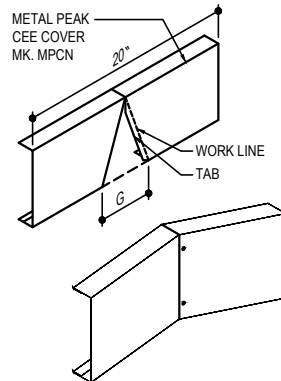

**FIELD FAB COVER LAYOUT**  
FOR BRAND DECAL

ROOF SLOPE	LAYOUT DIMENSION (INCHES)						
	A	B	C	D	E	F	G
0.25:12	1/8	1/4	5/16	7/16	1/2	11 3/4	5/16
0.50:12	1/4	7/16	5/8	13/16	1	11 1/2	5/8
1:12	1/2	7/8	1 1/4	1 5/8	2	11	13/16
2:12	15/16	1 13/16	2 7/16	3 5/16	3 15/16	10	2 3/8
3:12	1 7/16	2 11/16	3 11/16	4 15/16	6	9	39/16
4:12	1 7/8	3 5/8	4 7/8	6 5/8	7 7/8	8 1/16	4 3/4
5:12	2 3/8	4 1/2	6 1/8	8 1/4	9 7/8	7 1/16	5 15/16
6:12	2 7/8	5 3/8	7 3/8	9 7/8	11 7/8	6 1/16	7 1/8
7:12	3 3/8	6 1/4	8 5/8	11 1/2	13 7/8	5 1/16	8 5/16
8:12	3 7/8	7 1/8	9 7/8	13 1/8	15 7/8	4 1/16	9 1/2
9:12	4 5/16	8 1/16	11 1/8	14 7/8	17 7/8	3 1/8	10 11/16
10:12	4 3/4	9	12 1/4	16 1/2	19 3/4	2 1/8	11 7/8
11:12	5 1/4	9 7/8	13 1/2	18 1/8	21 3/4	7 1/8	13 1/16
12:12	5 3/4	10 3/4	14 3/4	19 3/4	23 3/4	6 1/8	14 1/4

**STEP BY STEP INSTRUCTIONS**

- 1. CREATE FIELD FAB PEAK BOX FROM SUPPLIED RAKE TRIM**
  - CUT RAKE TRIM INTO (2) 2'-0" ± LENGTHS
    - (2) 3'-0" ± LENGTHS AT 11:12 SLOPE AND GREATER
  - LAYOUT THE WORK LINES AS SHOWN
  - OFFSET ONE OF THE WORK LINES FOR TABS LAYOUT
  - MAKE CUTS AS SHOWN
  - BEND AT THE TOP HORIZONTAL LEG OF THE TRIM
  - POP RIVET THE TWO SIDES TOGETHER WITH H1100 RIVETS
  - CAULK ANY GAPS AS REQUIRED ON INSIDE WITH H3152 POLYURETHANE TUBE CAULK
- 3. CREATE FIELD FAB COVER FOR BRAND DECAL**
  - CUT A 20° PIECE OF MPC. AND CUT THE PIE SHAPE LEAVING A TAB ON SIDE TO RIVET TOGETHER.
  - ATTACH TO PEAK BOX WITH RIVETS TOP AND BOTTOM AND APPLY DECAL

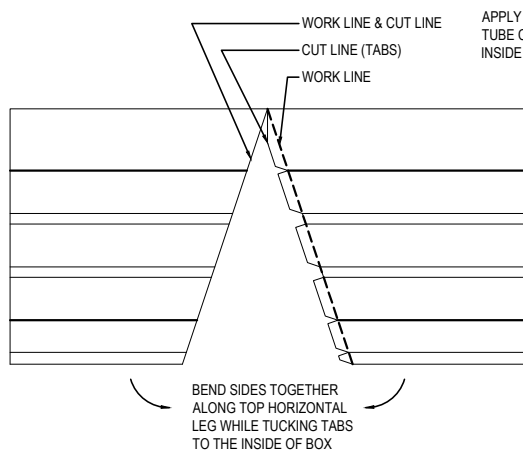
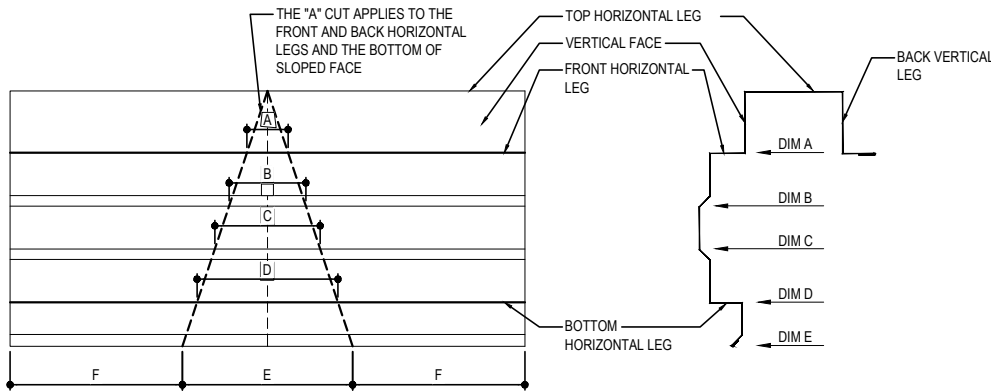

APPLY H3152 POLYURETHANE TUBE CAULK AS REQUIRED ON INSIDE TO SEAL ANY VOIDS

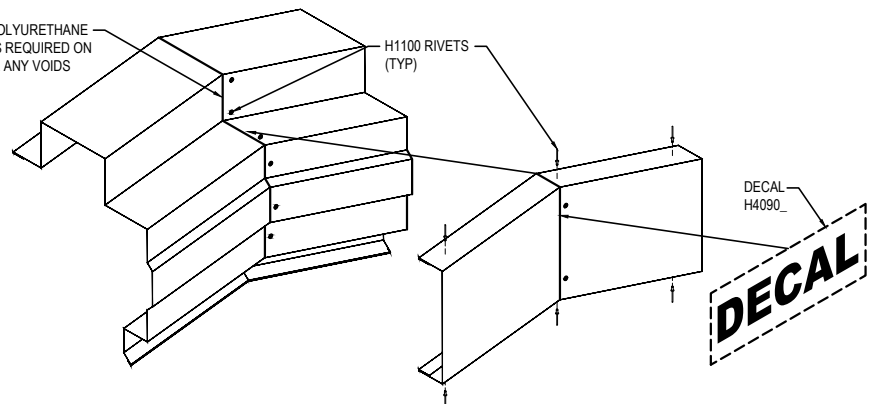

**FIELD FABRICATED PEAK BOX INSTRUCTIONS**  
REFERENCE PEAK BOX DETAIL FOR INSTALLATION

**DG7001**

**Detailer Notes:**

- DG7001 AND EG7001 ARE IDENTICAL DETAILS. THESE ARE USED TO KEEP THE DETAILS IN ORDER WITH THE RESPECTIVE ROOF SYSTEMS.
- THIS DETAIL IS USED WHEN FIELD FAB PEAK BOXES ARE REQUESTED. THE PEAK BOX INSTALLATION DETAIL IS ALSO REQUIRED.

**DG7232 - RIDGE CAP WITH METAL PEAK BOX INSTALLATION**

[Download the DWG file by clicking here.](#)

**METAL PEAK BOX PREPARATION**

**PEAK BOX PREPARATION  
STEP 1**

PRIOR TO INSTALLING THE FIRST OR LAST PIECE OF RIDGE CAP, THE PEAK BOX (EITHER PRE-FABRICATED OR FIELD FABRICATED) NEEDS TO BE PREPPED AND DRY-FIT TO ENSURE PROPER FIT UP.

NEXT APPLY A BEAD OF POLYURETHANE TUBE CAULK (H3152) ON THE UNDERSIDE OF THE PEAK BOX WHERE ANY GAPS MAY BE PRESENT.

FIELD NOTCH THE BACK OF THE PEAK BOX TO MATCH THE PROFILE OF THE RIDGE CAP.

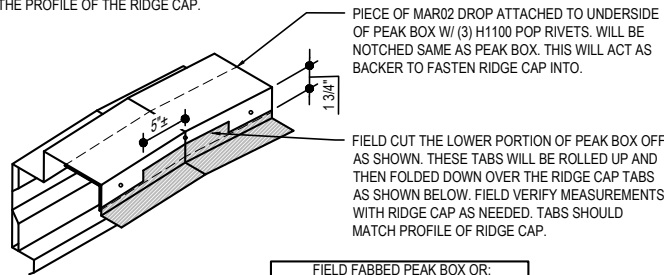

FIELD FABBED PEAK BOX OR:	
ROOF SLOPE	PEAK BOX
0.5:12	MPSN50
1:12	MPSN01
2:12	MPSN02

**RIDGE CAP PREPARATION  
STEP 2**

CREATE TABS AS SHOWN BELOW. THESE TABS WILL SEAL TO THE BACKSIDE OF THE RAKE TRIMS.

ONCE TABS HAVE BEEN CREATED, DRY-FIT THE RIDGE CAP TO THE BACK OF THE RAKE TRIM.

ROLL THE PEAK BOX OVER THE RAKE TRIM AND RIDGE CAP TABS AS SHOWN BELOW TO DRY-FIT.

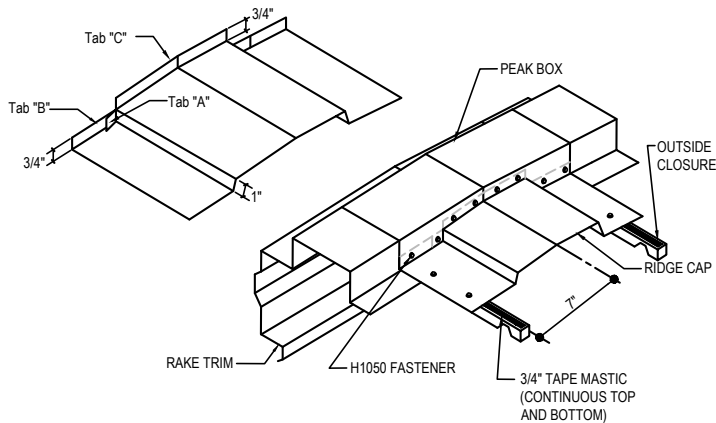

**RIDGE CAP WITH METAL PEAK BOX INSTALLATION**

DETAIL SHOWN WITH ROOF AND WALL PANEL. OTHER WALL SYSTEMS AND NO WALL SIMILAR.

**Detailer Notes:**

1) N/A

**METAL PEAK BOX INSTALLATION AT STANDARD RAKE TRIM  
STEP 3**

INSTALL CONTINUOUS 3/4" TAPE MASTIC (H3000) ALONG THE TOP AND BOTTOM OF THE OUTSIDE CLOSURES ON BOTH SIDES OF THE RIDGE. PLACE THE TAPE MASTIC AND CLOSURES ONTO ROOF PANEL. REMOVE THE PAPER BACKING ONLY AS WORK PROGRESSES. RIDGE CAP MUST BE PROPERLY POSITIONED BEFORE TOUCHING THE MASTIC. **MASTIC CANNOT BE REUSED.**

PLACE A BEAD OF POLYURETHANE TUBE CAULK (H3152) ON BACK OF TABS "B" WHERE IT WILL CONTACT THE RAKE TRIM.

CENTER THE RIDGE CAP OVER THE CLOSURES AND TIGHTLY AGAINST THE BACK OF THE RAKE TRIM.

NEXT APPLY A CONTINUOUS BEAD OF POLYURETHANE TUBE CAULK (H3152) ON THE UNDERSIDE OF THE PEAK BOX WHERE IT WILL COME INTO CONTACT WITH THE RAKE TRIMS.

PLACE A BEAD OF POLYURETHANE TUBE CAULK (H3152) BETWEEN TAB "A" AND TAB "B" ON THE RIDGE CAP. ALSO APPLY POLYURETHANE TUBE CAULK (H3152) ON TABS "B" AND "C" WHERE PEAK BOX WILL FIT.

CENTER THE PREPARED PEAK BOX AT THE RIDGE OVER THE RAKE TRIM AND TABS OF THE RIDGE CAP AND FASTEN THROUGH THE TABS AND INTO THE TABS OF THE RIDGE CAP WITH TRIM COLORED SELF-DRILLING SCREWS (H1050). ALSO ATTACH PEAK BOX BOTTOM FLANGE TO WALL PANEL WITH STITCH FASTENER SIMILAR TO RAKE TRIM.

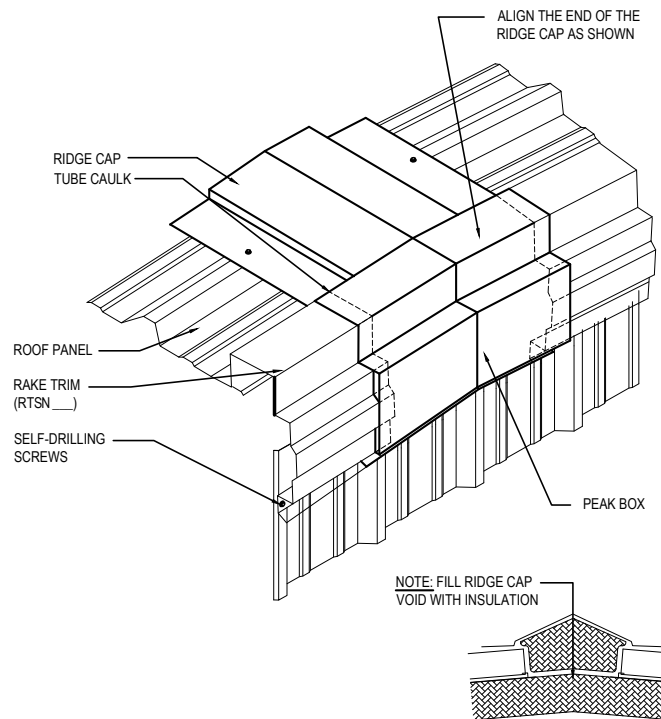

**DG7232**

DG7236 - DIE-FORMED RIDGE CAP WITH METAL PEAK BOX

[Download the DWG file by clicking here.](#)

**METAL PEAK BOX PREPARATION**

**PEAK BOX PREPARATION**  
STEP 1

THE FIRST OR LAST PIECE OF RIDGE CAP MUST BE INSTALLED PRIOR TO THE PEAK BOX INSTALLATION.

NEXT APPLY A CONTINUOUS BEAD OF POLYURETHANE TUBE CAULK (H3152) ON THE UNDERSIDE OF THE PEAK BOX WHERE IT COMES IN CONTACT WITH THE RAKE TRIMS. APPLY POLYURETHANE TUBE CAULK (H3152) TO ANY GAPS ON THE UNDERSIDE OF THE PEAK BOX.

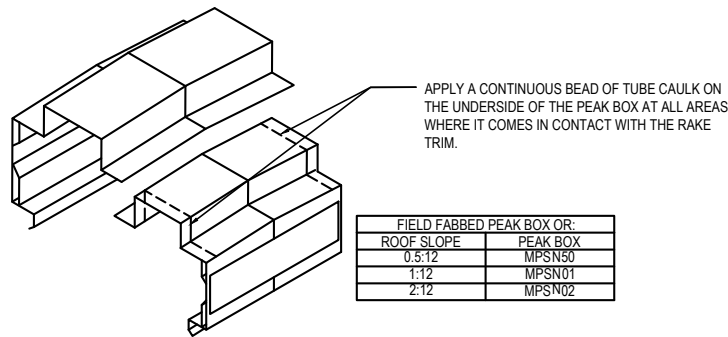

**PEAK BOX INSTALLATION**  
STEP 2

RAKE TRIM SHOULD BE RUN UP TO 5" FROM RIDGE LINE OVER THE RIDGE CAP. PLACE 2 1/4" TAPE MASTIC OVER RIDGE CAP & RAKE TRIM TO SEAL BETWEEN RAKE TRIM AND PEAK BOX.

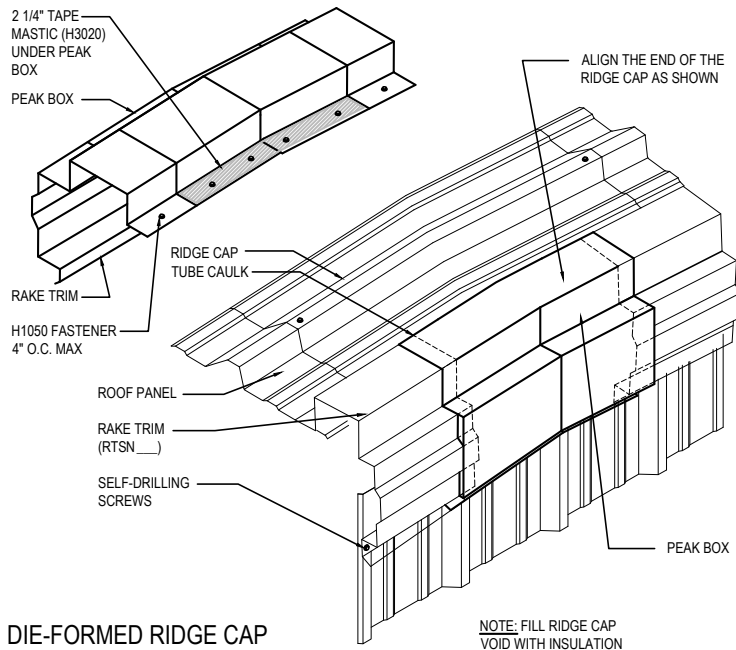

**DIE-FORMED RIDGE CAP WITH METAL PEAK BOX INSTALLATION**

DETAIL SHOWN WITH ROOF AND WALL PANEL. OTHER WALL SYSTEMS AND NO WALL SIMILAR.

**DG7236**

**Detailer Notes:**

- 1) N/A

**DG7241 - PEAK TRANSITION TO PARAPET TRIM AT VENTED RIDGE**

[Download the DWG file by clicking here.](#)

**PARAPET PEAK TRANSITION**

**PREPERATION AND ASSEMBLING RIDGE CAP  
STEP 1**

START BY RUNNING THE RAKE PARAPET ANGLE (MAP01) TO THE CENTERLINE OF RIDGE. (LOW SLOPE). EXTEND THE RAKE PARAPET TRIM (RPU121) TO THE CENTERLINE OF RIDGE.

ON HIGHER SLOPE BUILDINGS, RUN PARAPET ANGLE PAST RIDGE AND COPE BOTTOM LEG SO THAT THERE IS NOT A LARGE GAP ON THE BACK OF THE RAKE ANGLE.

FIELD NOTCH A PIECE OF RIDGE CAP AS SHOWN IN FIGURE A. BEND ALL TABS 90°. START THE RIDGE CAP TABS A MAXIMUM OF 1/2" FROM THE EDGE OF THE RAKE PARAPET TRIM AS SHOWN. PLACE TOP PORTION OF RIDGE CAP ON TOP OF RAKE PARAPET TRIM.

PROPER RIDGE CAP FIT UP WITH THE METAL PEAK BOX, THE RIDGE CAP WILL NEED TO BE FIELD NOTCHED. START BY MARKING A LINE ON THE RIDGE CAP BACK 2 1/2" FROM THE LEADING EDGE ON THE HORIZONTAL AND VERTICAL SURFACES OF THE RIDGE CAP.

CUT AND TAB END OF RIDGE CAP AS SHOWN.

BEFORE SETTING THE RIDGE CAP, PLACE A PIECE OF 3/4" TAPE MASTIC (H3000) BETWEEN TAB "B" AND THE RAKE TRIM. RIDGE CAP MUST BE PROPERLY POSITIONED BEFORE TOUCHING THE MASTIC AND TUBE CAULK. MASTIC CANNOT BE REUSED.

CENTER THE RIDGE CAP OVER THE CLOSURES/VENT MATERIAL AND TIGHTLY AGAINST THE FACE OF THE RAKE PARAPET TRIM. FASTEN TAB "B" TO THE FACE OF THE PARAPET RAKE TRIM WITH (1) (H1050) TRIM COLORED SELF-DRILLING SCREW. REPEAT THESE STEPS FOR THE OTHER SIDE OR RIDGE CAP.

CAULK BETWEEN TAB "A" AND "B" WITH POLYURETHANE TUBE CAULK (H3152) AND FASTEN TAB "A" THROUGH TAB "B" AND INTO THE RAKE PARAPET TRIM WITH (1) (H1050) SELF-DRILLING SCREW.

CONTINUE FASTENING THE RIDGE CAP AT THE HIGH RIBS WITH TRIM-COLORED SELF-DRILLING SCREWS (H1050) AT 12" ON CENTER.

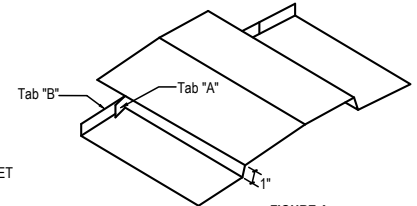

**FIGURE A**

**CLOSING OFF THE PARAPET AND RIDGE CAP  
STEP 2**

TO INSTALL THE EXPANDABLE EDGED FLASH, (RPT30) APPLY 2 1/4" TAPE MASTIC (H3020) TO RAKE PARAPET TRIM AS SHOWN.

APPLY GENEROUS BEAD OF POLYURETHANE TUBE CAULK (H3152) TO THE CORNERS RAKE PARAPET TRIM. FORM THE EXPANDABLE EDGED FLASH PIECE TO SHAPE OF THE PARAPET TRIM & RIDGE CAP. CENTER OVER THE RIDGE CAP. NEXT, PUSH EXPANDABLE EDGED FLASH TIGHT INTO CORNERS AND FORM BELLOWS IN THE CENTER OF THE FLASH AS SHOWN. FASTEN WITH (10) TRIM-COLORED SELF-DRILLING SCREWS (H1050). DO NOT FASTEN INTO THE PARAPET TRIM.

NEXT, TAKE SHORT PIECES OF JAMB TRIM AND PLACE ON EACH SIDE OF THE EXPANDABLE EDGED FLASH. FASTEN INTO THE RAKE ANGLE WITH ALL FASTENERS AS SHOWN. TAKE A PIECE OF HEAD TRIM AND FIELD TAB INTO JAMB TRIM. FASTEN WITH WALL FASTENERS. CAULK THE PERIMETER OF THE EXPANDABLE EDGED FLASH (RPT30) WITH POLYURETHANE TUBE CAULK (H3152).

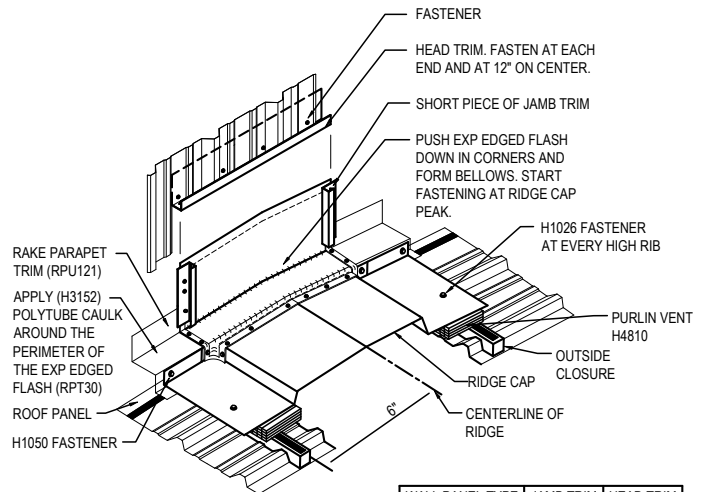
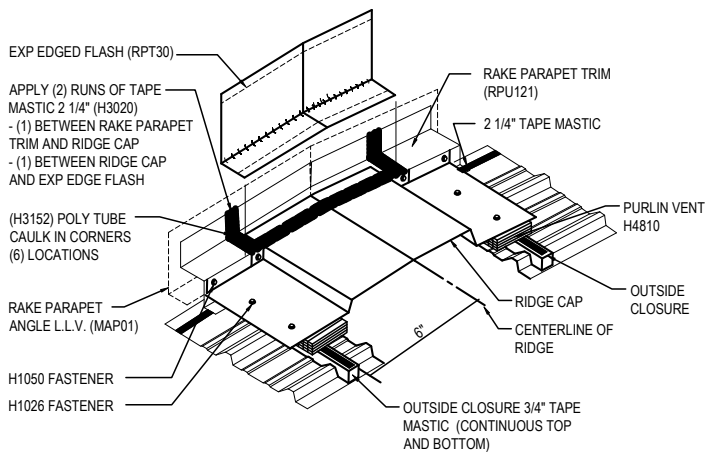

WALL PANEL TYPE	JAMB TRIM	HEAD TRIM
R-PANEL	JTA087	HTA044
A-PANEL	JTA087	HTA044
REV R-PANEL	JTD087	HTA044
IMP	JHI__	JHI__

**NOTES:**  
ON HIGHER SLOPE BUILDINGS, TAPER MASTIC BACK FROM HIGH POINT OF RIDGE CAP AS SHOWN. TAPER EXPANDABLE EDGED FLASH OVER TOP OF TAPE MASTIC AS WELL. FASTENERS INTO MASONRY AND COUNTER FLASH BY OTHERS. FIELD WORK RAKE PARAPET TRIMS TO ENSURE WEATHER TIGHTNESS AS REQUIRED ON ALL BUILDINGS.

**PEAK TRANSITION TO PARAPET TRIM AT VENTED RIDGE**

TRANSITION AT PEAK TO WALL PANEL ABOVE. MASONRY AND INSULATED PANEL SIM. SEE ADDITIONAL DETAILS FOR TRIM REQUIREMENTS.

**DG7241**

**Detailer Notes:**

1) N/A

**DG7242 - VENTED RIDGE CAP WITH METAL PEAK BOX INSTALLATION (NBS)**

[Download the DWG file by clicking here.](#)

**METAL PEAK BOX PREPARATION**

**PEAK BOX PREPARATION  
STEP 1**

PRIOR TO INSTALLING THE FIRST OR LAST PIECE OF RIDGE CAP, THE PEAK BOX (EITHER PRE-FABRICATED OR FIELD FABRICATED) NEEDS TO BE PREPPED AND DRY-FIT TO ENSURE PROPER FIT UP.

NEXT APPLY A BEAD OF POLYURETHANE TUBE CAULK (H3152) ON THE UNDERSIDE OF THE PEAK BOX WHERE ANY GAPS MAY BE PRESENT.

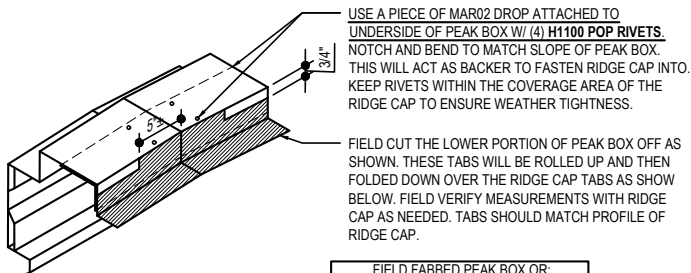

FIELD FABBED PEAK BOX OR:	
ROOF SLOPE	PEAK BOX
0.5:12	MPSN50
1:12	MPSN01
2:12	MPSN02

**RIDGE CAP PREPARATION  
STEP 2**

CREATE TABS AS SHOWN BELOW. THESE TABS WILL SEAL TO THE TOP AND BACKSIDE OF THE RAKE TRIMS.

ONCE TABS HAVE BEEN CREATED, DRY-FIT THE RIDGE CAP TO THE BACK OF THE RAKE TRIM.

ROLL THE PEAK BOX OVER THE RAKE TRIM AND RIDGE CAP TABS AS SHOWN BELOW TO DRY-FIT.

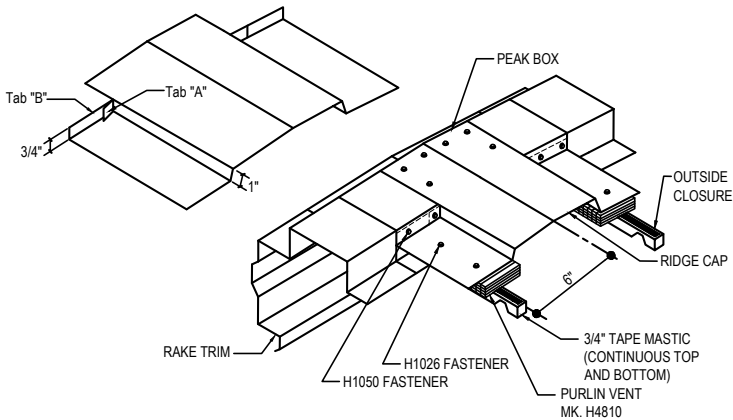

**METAL PEAK BOX INSTALLATION AT STANDARD RAKE TRIM  
STEP 3**

INSTALL CONTINUOUS 3/4" TAPE MASTIC (H3000) ALONG THE TOP AND BOTTOM OF THE OUTSIDE CLOSURES AND VENT MATERIAL ON BOTH SIDES OF THE RIDGE. PLACE THE TAPE MASTIC, CLOSURES, AND VENT MATERIAL ONTO ROOF PANEL. REMOVE THE PAPER BACKING ONLY AS WORK PROGRESSES. RIDGE CAP MUST BE PROPERLY POSITIONED BEFORE TOUCHING THE MASTIC. MASTIC CANNOT BE REUSED.

PLACE A BEAD OF POLYURETHANE TUBE CAULK (H3152) ON BACK OF TABS 'B' WHERE IT WILL CONTACT THE RAKE TRIM.

CENTER THE RIDGE CAP OVER THE CLOSURES/VENT MATERIAL AND TIGHTLY AGAINST THE TOP AND BACK OF THE RAKE TRIM.

NEXT APPLY A CONTINUOUS BEAD OF POLYURETHANE TUBE CAULK (H3152) ON THE UNDERSIDE OF THE PEAK BOX WHERE IT WILL COME INTO CONTACT WITH THE RAKE TRIMS.

PLACE A BEAD OF POLYURETHANE TUBE CAULK (H3152) BETWEEN TAB 'A' AND TAB 'B' ON THE RIDGE CAP. ALSO APPLY POLYURETHANE TUBE CAULK (H3152) AROUND TOP OF RIDGE CAP WHERE IT SITS ON TOP OF PEAK BOX.

CENTER THE PREPARED PEAK BOX AT THE RIDGE OVER THE RAKE TRIM AND TABS OF THE RIDGE CAP AND FASTEN THROUGH THE TABS AND INTO THE TABS OF THE RIDGE CAP WITH TRIM COLORED SELF-DRILLING SCREWS (H1050). ALSO ATTACH PEAK BOX BOTTOM FLANGE TO WALL PANEL WITH STITCH FASTENER SIMILAR TO RAKE TRIM.

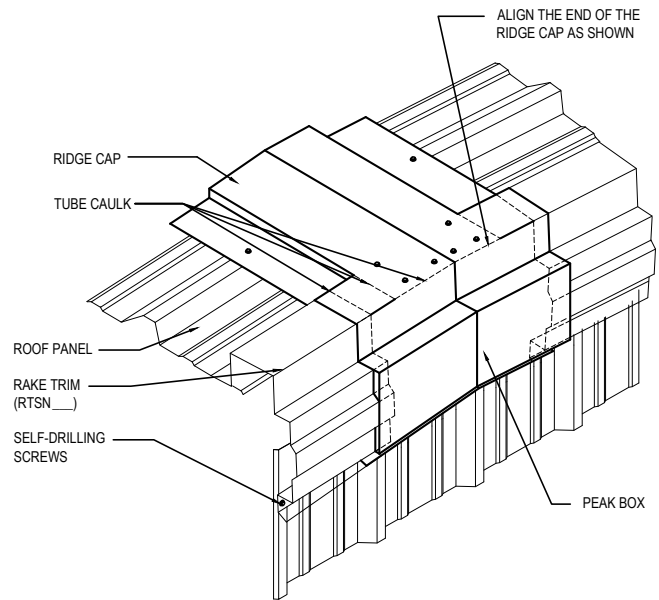

**VENTED RIDGE CAP WITH METAL PEAK BOX INSTALLATION**

DETAIL SHOWN WITH ROOF AND WALL PANEL. OTHER WALL SYSTEMS AND NO WALL SIMILAR.

**DG7242**

**Detailer Notes:**

1) N/A