

HIGH EAVE (SCULPTURED)

- DH0006 - HE MEMBER w WALL PANEL
 - DH0007 - HE MEMBER w WALL PANEL
 - DH0020 - HE MEMBER AT MASONRY WALL
 - DH0025 - HE MEMBER w NO WALL PANEL
 - DH0026 - HE MEMBER w NO WALL PANEL
 - DH0035 - HE MEMBER w PARTIAL WIDTH WALL PANEL
 - DH0036 - HE MEMBER w PARTIAL WIDTH WALL PANEL
-

DH0006 - HIGH EAVE SCULPTURED W/ WALL PANEL

[Download the DWG file by clicking here.](#)

HIGH EAVE LAP & FLASHING BACKER

SLIDE FIELD CUT SECTION FLASHING ENDLAP BACKER ONTO THE LOWER TRIM PIECE. PLACE TAPE MASTIC NEXT TO HEM OF THE BACKER (NOT ON TOP OF HEM). APPLY CONTINUOUS BEAD OF CAULK 1" FROM END OF TRIM DOWN PROFILE OF TRIM. FASTEN LAP WITH STITCH FASTENERS AND POP RIVETS AS SHOWN.

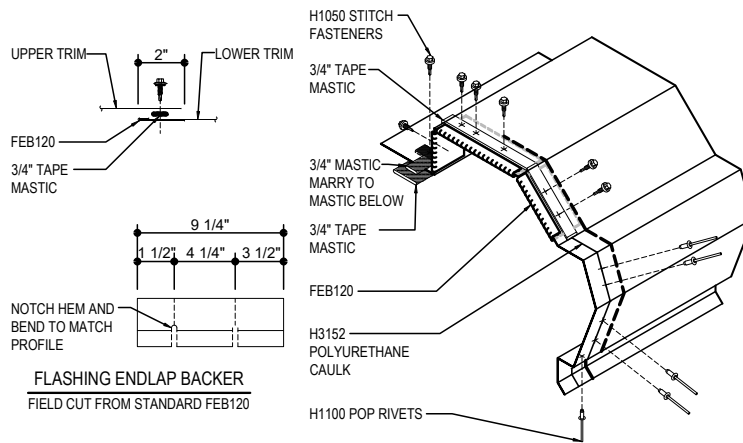

ERECTOR NOTE:

H1020 FASTENERS (PURLINS) & H1070 FASTENERS (JOISTS) WITH H2200 INSULATION WASHERS HAVE BEEN SUPPLIED 12" O.C. FOR INSULATION ATTACHMENT AT RIDGE.

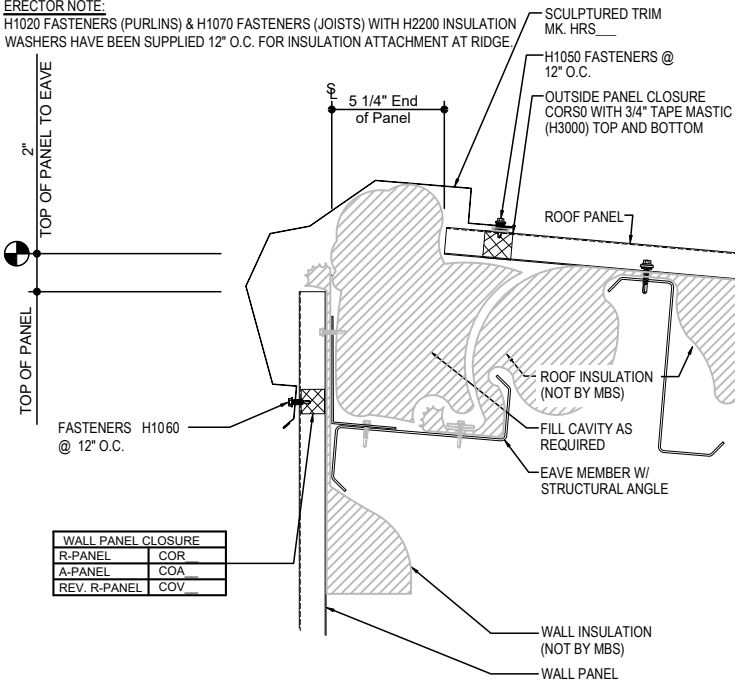

WALL PANEL CLOSURE	
R-PANEL	COR
A-PANEL	COA
REV. R-PANEL	COV

HIGH EAVE SCULPTURED DETAIL

HIGH EAVE SCULPTURED DETAIL w/ R-Panel ROOF & WALL PANELS
SEE WALL SHEETING ERECTION NOTES FOR WALL PANEL FASTENER LOCATIONS

DH0006

Detailer Notes:

- 1) CLOSURES HIGH EAVE LAYER DEFAULT IS ON. LAYER MUST BE TURNED OFF IF CLOSURES ARE NOT REQUIRED.
- 2) THIS DETAIL SHOULD NOT BE USED WITH HIGH SIDE EAVE STRUTS. SEE DH0007 WHEN HIGH EAVE STRUTS ARE BEING USED.

DH0007 - HIGH EAVE SCULPTURED W/ WALL PANEL

[Download the DWG file by clicking here.](#)

HIGH EAVE LAP & FLASHING BACKER

SLIDE FIELD CUT SECTION FLASHING ENDLAP BACKER ONTO THE LOWER TRIM PIECE. PLACE TAPE MASTIC NEXT TO HEM OF THE BACKER (NOT ON TOP OF HEM). APPLY CONTINUOUS BEAD OF CAULK 1" FROM END OF TRIM DOWN PROFILE OF TRIM. FASTEN LAP WITH STITCH FASTENERS AND POP RIVETS AS SHOWN.

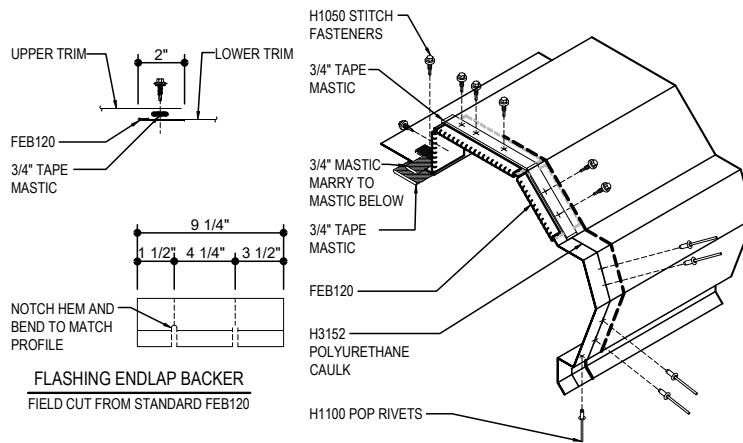

ERECTOR NOTE:
H1020 FASTENERS (PURLINS) & H1070 FASTENERS (JOISTS) WITH H2200 INSULATION WASHERS HAVE BEEN SUPPLIED 12" O.C. FOR INSULATION ATTACHMENT AT HIGH EAVE.

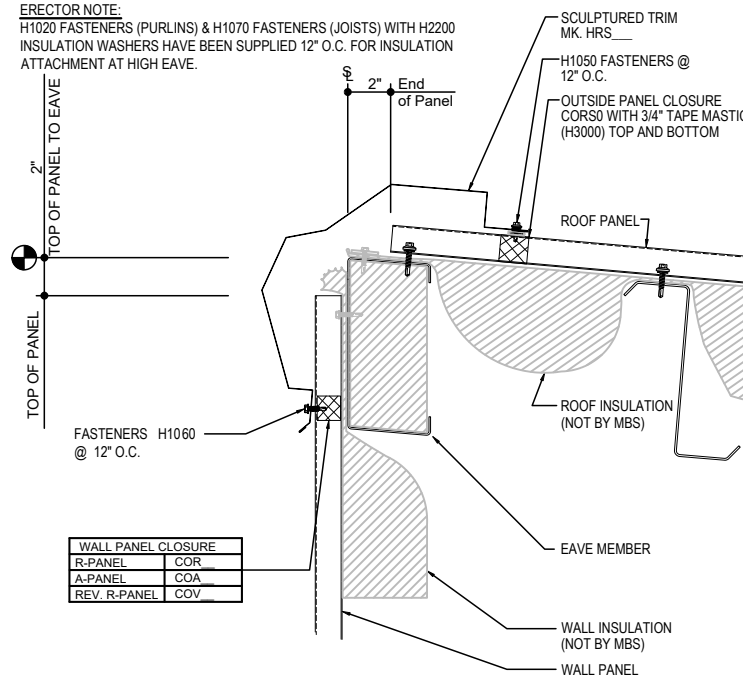

WALL PANEL CLOSURE	
R-PANEL	COR
A-PANEL	COA
REV. R-PANEL	COV

HIGH EAVE SCULPTURED DETAIL

HIGH EAVE SCULPTURED DETAIL w/ R-Panel ROOF & WALL PANELS
SEE WALL SHEETING ERECTION NOTES FOR WALL PANEL FASTENER LOCATIONS

DH0007

Detailer Notes:

- 1) CLOSURES HIGH EAVE LAYER DEFAULT IS ON. LAYER MUST BE TURNED OFF IF CLOSURES ARE NOT REQUIRED.

DH0020 - HIGH EAVE SCULPTURED AT MASONRY WALL

[Download the DWG file by clicking here.](#)

HIGH EAVE LAP & FLASHING BACKER

SLIDE FIELD CUT SECTION FLASHING ENDLAP BACKER ONTO THE LOWER TRIM PIECE. PLACE TAPE MASTIC NEXT TO HEM OF THE BACKER (NOT ON TOP OF HEM). APPLY CONTINUOUS BEAD OF CAULK 1" FROM END OF TRIM DOWN PROFILE OF TRIM. FASTEN LAP WITH STITCH FASTENERS AND POP RIVETS AS SHOWN.

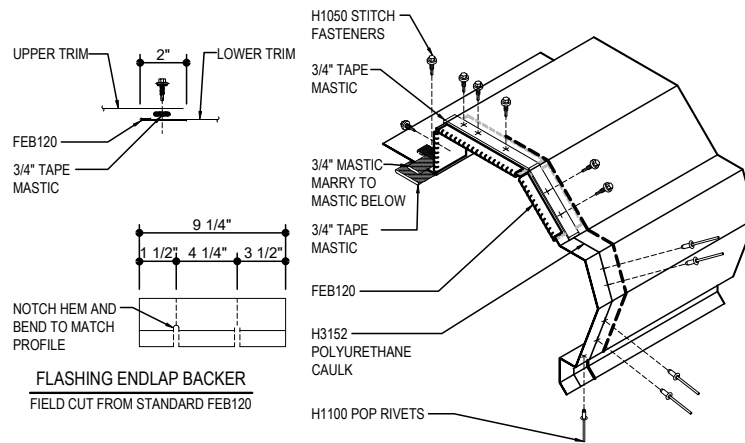

FLASHING ENDLAP BACKER
FIELD CUT FROM STANDARD FEB120

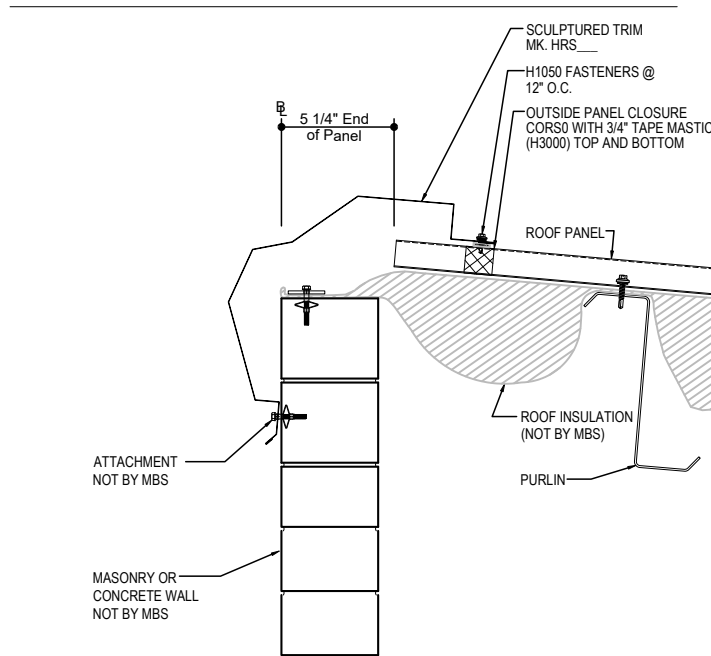

HIGH EAVE SCULPTURED DETAIL

HIGH EAVE SCULPTURED DETAIL w/ R-Panel ROOF AT MASONRY WALL
SEE WALL SHEETING ERECTION NOTES FOR WALL PANEL FASTENER LOCATIONS

DH0020

Detailer Notes:

- 1) N/A

DH0025 - HIGH EAVE SCULPTURED W/ NO WALL PANEL

[Download the DWG file by clicking here.](#)

HIGH EAVE LAP & FLASHING BACKER

SLIDE FIELD CUT SECTION FLASHING ENDLAP BACKER ONTO THE LOWER TRIM PIECE. PLACE TAPE MASTIC NEXT TO HEM OF THE BACKER (NOT ON TOP OF HEM). APPLY CONTINUOUS BEAD OF CAULK 1" FROM END OF TRIM DOWN PROFILE OF TRIM. FASTEN LAP WITH STITCH FASTENERS AND POP RIVETS AS SHOWN.

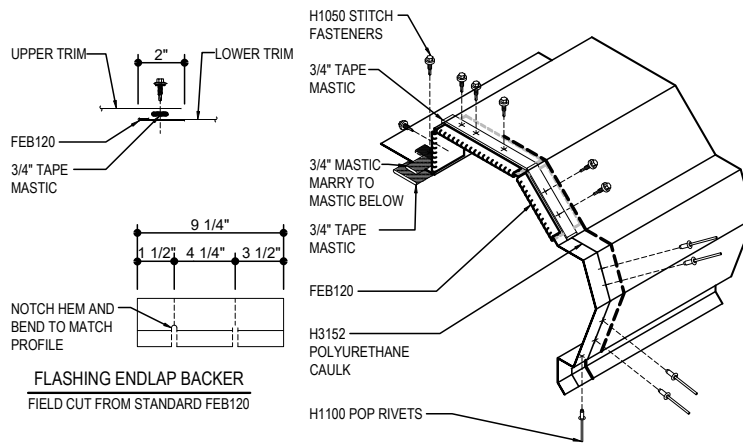

FLASHING ENDLAP BACKER
FIELD CUT FROM STANDARD FEB120

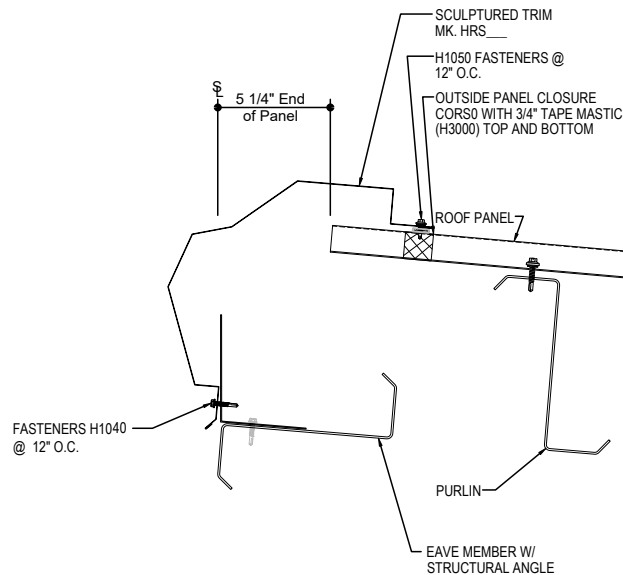

HIGH EAVE SCULPTURED DETAIL

HIGH EAVE SCULPTURED DETAIL w/ R-Panel ROOF & NO WALL PANELS
SEE WALL SHEETING ERECTION NOTES FOR WALL PANEL FASTENER LOCATIONS

DH0025

Detailer Notes:

- 1) THIS DETAIL SHOULD NOT BE USED WITH HIGH SIDE EAVE STRUTS.
SEE DH0026 WHEN HIGH EAVE STRUTS ARE BEING USED.

DH0026 - HIGH EAVE SCULPTURED W/ NO WALL PANEL

[Download the DWG file by clicking here.](#)

HIGH EAVE LAP & FLASHING BACKER

SLIDE FIELD CUT SECTION FLASHING ENDLAP BACKER ONTO THE LOWER TRIM PIECE. PLACE TAPE MASTIC NEXT TO HEM OF THE BACKER (NOT ON TOP OF HEM). APPLY CONTINUOUS BEAD OF CAULK 1" FROM END OF TRIM DOWN PROFILE OF TRIM. FASTEN LAP WITH STITCH FASTENERS AND POP RIVETS AS SHOWN.

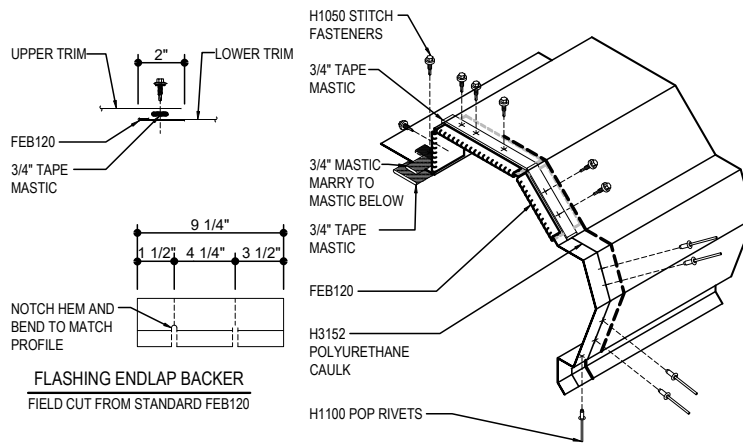

FLASHING ENDLAP BACKER
FIELD CUT FROM STANDARD FEB120

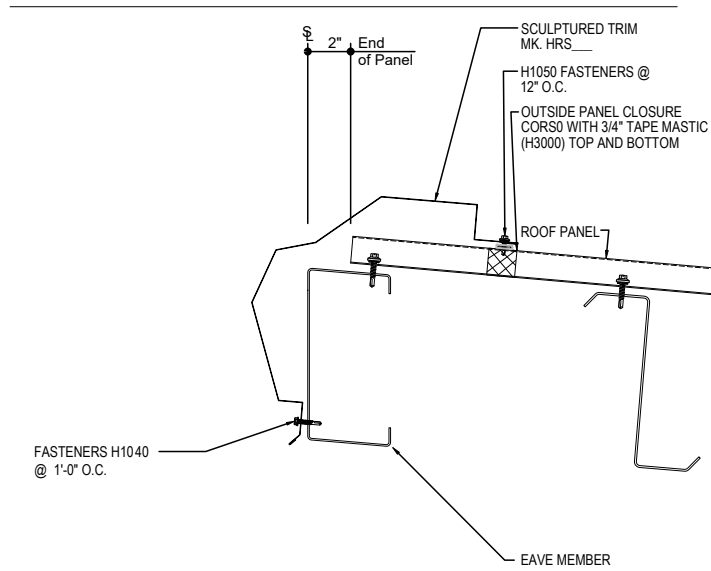

HIGH EAVE SCULPTURED DETAIL

HIGH EAVE SCULPTURED DETAIL w/ R-Panel ROOF NO WALL PANELS
SEE WALL SHEETING ERECTION NOTES FOR WALL PANEL FASTENER LOCATIONS

DH0026

Detailer Notes:

- 1) N/A

DH0035 - HIGH EAVE SCULPTURED W/ PARTIAL WIDTH WALL PANEL

[Download the DWG file by clicking here.](#)

HIGH EAVE LAP & FLASHING BACKER

SLIDE FIELD CUT SECTION FLASHING ENDLAP BACKER ONTO THE LOWER TRIM PIECE. PLACE TAPE MASTIC NEXT TO HEM OF THE BACKER (NOT ON TOP OF HEM). APPLY CONTINUOUS BEAD OF CAULK 1" FROM END OF TRIM DOWN PROFILE OF TRIM. FASTEN LAP WITH STITCH FASTENERS AND POP RIVETS AS SHOWN.

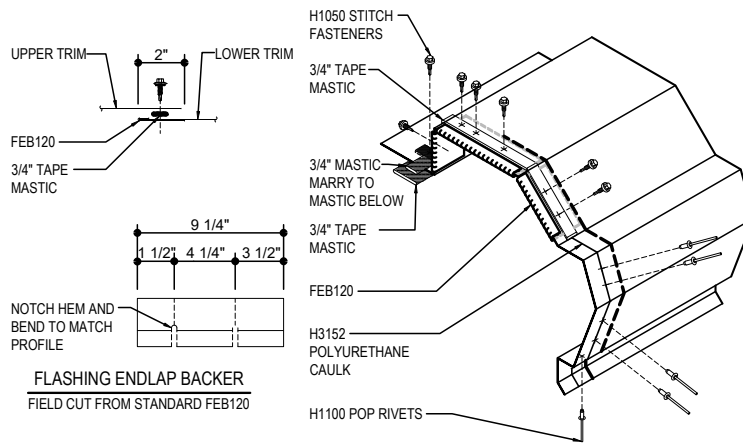

FLASHING ENDLAP BACKER
FIELD CUT FROM STANDARD FEB120

ERECTOR NOTE:

H1020 FASTENERS (PURLINS) & H1070 FASTENERS (JOISTS) WITH H2200 INSULATION WASHERS HAVE BEEN SUPPLIED 12" O.C. FOR INSULATION ATTACHMENT AT HIGH EAVE.

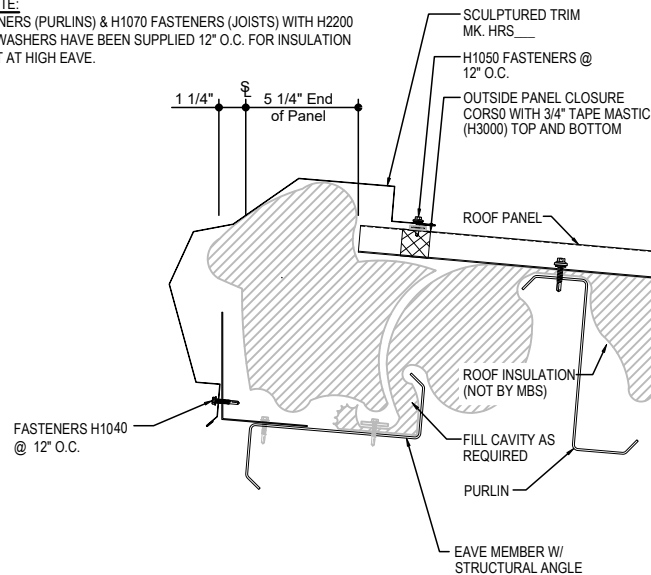

HIGH EAVE SCULPTURED DETAIL

HIGH EAVE SCULPTURED DETAIL w/ R-Panel ROOF w/ PARTIAL WIDTH WALL PANEL
SEE WALL SHEETING ERECTION NOTES FOR WALL PANEL FASTENER LOCATIONS

DH0035

Detailer Notes:

- 1) THIS DETAIL SHOULD NOT BE USED WITH HIGH SIDE EAVE STRUTS.
SEE DH0036 WHEN HIGH EAVE STRUTS ARE BEING USED.

DH0036 - HIGH EAVE SCULPTURED W/ PARTIAL WIDTH WALL PANEL

[Download the DWG file by clicking here.](#)

HIGH EAVE LAP & FLASHING BACKER

SLIDE FIELD CUT SECTION FLASHING ENDLAP BACKER ONTO THE LOWER TRIM PIECE. PLACE TAPE MASTIC NEXT TO HEM OF THE BACKER (NOT ON TOP OF HEM). APPLY CONTINUOUS BEAD OF CAULK 1" FROM END OF TRIM DOWN PROFILE OF TRIM. FASTEN LAP WITH STITCH FASTENERS AND POP RIVETS AS SHOWN.

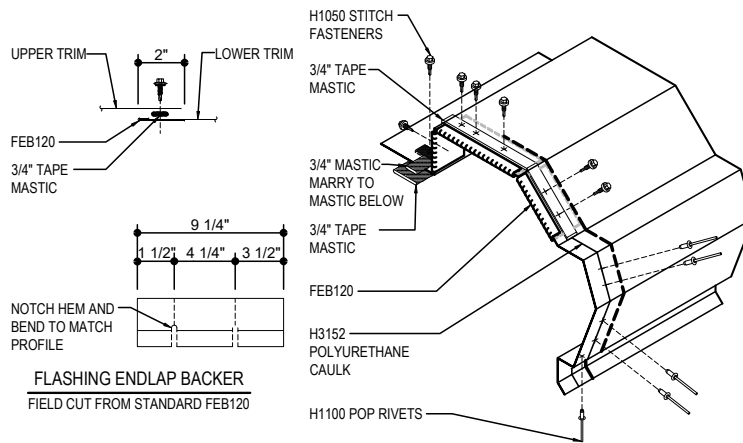

ERECTOR NOTE:

H1020 FASTENERS (PURLINS) & H1070 FASTENERS (JOISTS) WITH H2200 INSULATION WASHERS HAVE BEEN SUPPLIED 12" O.C. FOR INSULATION ATTACHMENT AT HIGH EAVE.

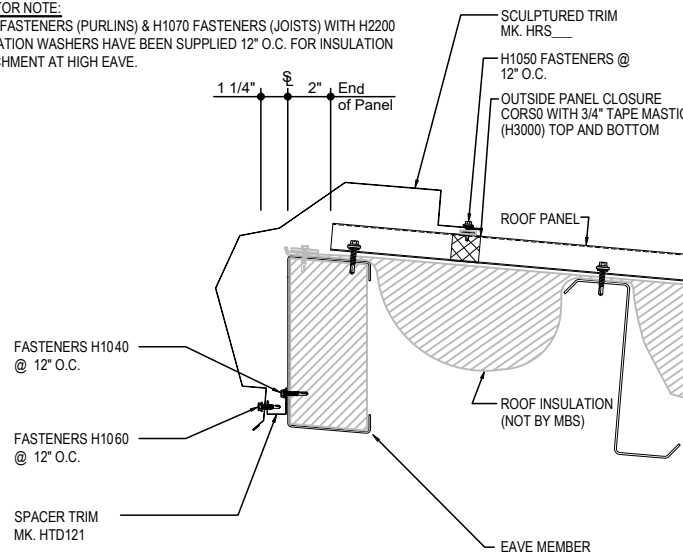

HIGH EAVE SCULPTURED DETAIL

HIGH EAVE SCULPTURED DETAIL w/ R-Panel ROOF w/ PARTIAL WIDTH WALL PANEL
 SEE WALL SHEETING ERECTION NOTES FOR WALL PANEL FASTENER LOCATIONS

DH0036

Detailer Notes:

- 1) N/A