

HIGH EAVE (PARAPET)

DI7251 - HE PARAPET TO RAKE PARAPET - OUTSIDE

DI7252 - NBS - HE PARAPET WITH RAKE TERM AT CORNER - OUTSIDE

DI7281 - HE PARAPET TO RAKE PARAPET - INSIDE

DI7282 - NBS - HE PARAPET WITH RAKE TERM - INSIDE

DI7251 HIGH EAVE PARAPET TO RAKE PARAPET - OUTSIDE

Download the DWG file by clicking here.

PREPARATION FOR HIGH EAVE PARAPET LOWER BUILDING EXTENDS

**MODIFIED CLOSURE AT PARAPET CORNER
STEP 1**

PLACE OUTSIDE PANEL CLOSURES ALONG THE HIGH EAVE TO REACH THE BACK OF THE RAKE PARAPET TRIM. REFERENCE THE TYPICAL HIGH EAVE PARAPET DETAIL FOR PROPER OUTSIDE CLOSURE INSTALLATION.

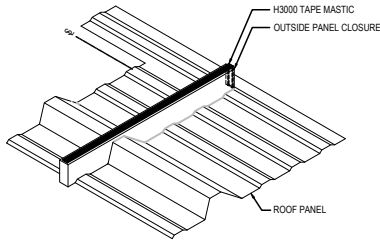

**RAKE PARAPET TRIM MOCK UP TO CUT INSTALLATION
STEP 4 AND STEP 5**

STEP 4: BEFORE INSTALLING THE RAKE PARAPET TRIM (RPU121), PLACE TAPE MASTIC ON TOP OF THE ROOF PANEL. FROM THE LOW END OF THE RAKE PARAPET TRIM TO THE HIGH END OF THE PANEL (DO NOT REMOVE THE PAPER BACK FROM THE MASTIC UNTIL THE TABS IN THE RAKE PARAPET TRIM ARE CREATED).

PLACE THE LOW END OF THE RAKE PARAPET TRIM "FLUSH" WITH THE LOW END OF THE HIGH EAVE PARAPET TRIM AS SHOWN.

TRACE THE HIGH EAVE PARAPET TRIM PROFILE ONTO THE BACK VERTICAL LEG OF THE RAKE PARAPET TRIM.

STEP 5: CUT THE RAKE PARAPET TRIM TO CREATE TABS AS SHOWN.

APPLY TUBE CAULK TO ALL VOIDS.

FASTEN THE TABS TO THE HIGH EAVE PARAPET TRIM WITH H1050 FASTENERS.

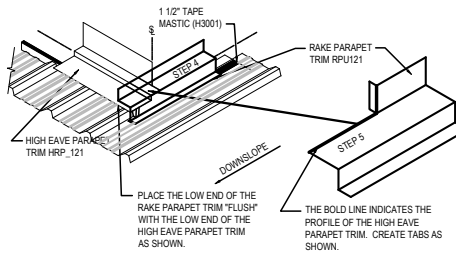

**HIGH EAVE PARAPET LOW BUILDING EXTENDS
STEP 7 WALL PANEL - OPTION 1**

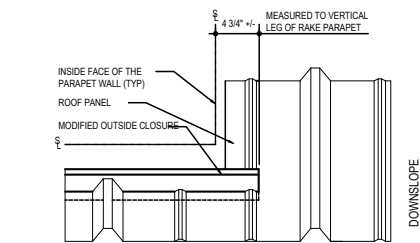
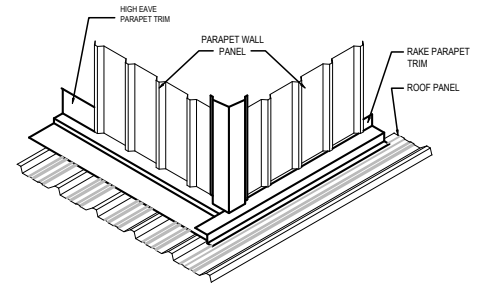

**INSTALL WALL PANELS AND COPE CORNER TRIM
STEP 6**

INSTALL THE WALL PANELS PER THE INSTRUCTIONS IN THE WALL PANEL DETAILS INCLUDED IN THIS SET OF ERECTION DRAWINGS.

COPE THE OUTSIDE CORNER TRIM (COB...) FLUSH WITH THE BOTTOM OF THE WALL PANELS ON BOTH THE SIDEWALL AND THE ENDWALL.

INSTALL THE OUTSIDE CORNER TRIM AS INDICATED IN THE WALL CORNER DETAIL.

NOTE THAT PANELS ARE SHOWN IN THIS DETAIL FOR REFERENCE ONLY. THE ACTUAL WALL PANEL PROFILE FOR THIS PROJECT MAY VARY.

**HIGH EAVE PARAPET TRIM INSTALLATION
STEP 3**

BEFORE INSTALLING THE HIGH EAVE PARAPET TRIM (HVP, 121), PLACE TAPE MASTIC ALONG THE FULL LENGTH OF THE TOP LEG OF THE RIGID CLOSURE.

PLACE THE FLAT LEG OF THE HIGH EAVE PARAPET TRIM "FLUSH" WITH THE END OF THE RIGID CLOSURE ALONG THE ENDWALL AS SHOWN.

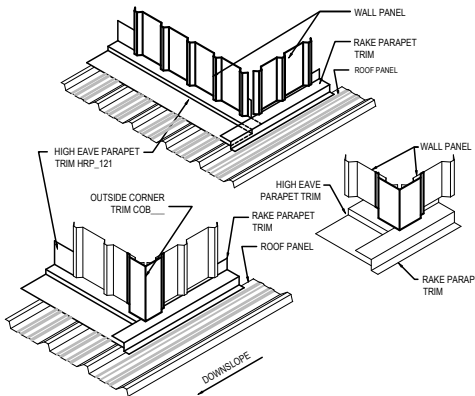
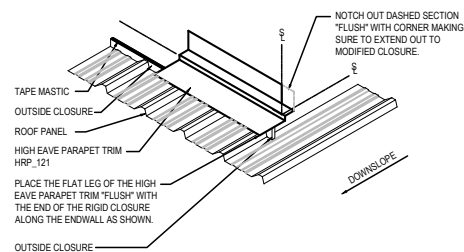

**HIGH EAVE PARAPET LOW BUILDING EXTENDS
WALL BY OTHERS - OPTION 2**

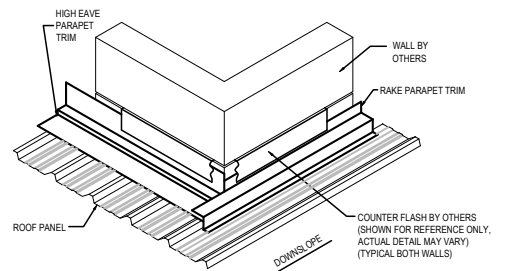

HIGH EAVE PARAPET- LOW EXTENDS

DETAIL SHOWN WITH WALL PANEL AND CORNER TRIM. MASONRY AND INSULATED WALL PANEL CONDITIONS SIMILAR.

DI7251

Detailer Notes:

- 1) N/A

DI7252 HIGH EAVE PARAPET WITH RAKE TERMINATION AT CORNER - OUTSIDE

[Download the DWG file by clicking here.](#)

HIGH EAVE PARAPET WITH RAKE TERMINATION AT CORNER

**RAKE TERMINATION AT WALL
STEP 1**

EXTEND THE RAKE TRIM TO STEEL LINE WHERE THE PROFILE WILL LAP 1" ON THE WALL CORNER TRIM THAT WILL BE INSTALLED LATER. ATTACH THE RAKE TRIM END CAP (H4000_) INTO THE HIGH SIDE OF THE RAKE TRIM. FASTEN WITH POP RIVETS (H1100). DO NOT ATTACH RAKE TRIM TO WALL UNTIL AFTER CORNER TRIM IS INSTALL. RAKE TRIM WILL NEED TO BE ROLLED OUT TO SLIDE CORNER TRIM BEHIND FACE OF RAKE TRIM.

**OUTSIDE CLOSURE INSTALLATION AND PREPARATION
STEP 2**

TEMPORARILY PLACE THE HIGH EAVE PARAPET TRIM IN POSITION TO DETERMINE THE CORRECT LOCATION OF THE OUTSIDE CLOSURES. THE CLOSURES SHOULD BE 2" AWAY FROM THE LOW END OF THE TRIM AS SHOWN.

CUT OUTSIDE CLOSURE TO FIT BACK OF RAKE TRIM AND RUN 3/4" TAPE MASTIC (H3000) CONTINUOUSLY BOTTOM AND TOP OF CLOSURE AND BETWEEN RAKE TRIM AS SHOWN.

**HIGH EAVE PARAPET TRIM INSTALLATION
STEP 3**

REFERENCE HIGH EAVE PARAPET DETAIL FOR TYPICAL PARAPET INSTALLATION. THE HIGH EAVE PARAPET TRIM SHOULD EXTEND ALL THE WAY OVER TO THE EDGE OF THE TOP HORIZONTAL LEG OF THE RAKE TRIM AS SHOWN. THE LOWER PORTION OF PARAPET TRIM WILL TERMINATE INTO BACK OF RAKE TRIM. BEND AND TAB AS SHOWN BELOW. USE POLYURETHANE TUBE CAULK (H3152) AND FASTEN THE PARAPET TRIM TO RAKE TRIM WITH (H1050) FASTENERS.

**WALL PANEL & CORNER TRIM INSTALLATION
STEP 4**

INSTALL WALL PANEL AND CORNER TRIM ACCORDING THOSE DETAILS. CORNER TRIM SHOULD EXTEND DOWN TO THE BOTTOM HORIZONTAL LEG OF THE RAKE TRIM BUT WILL NEED TO BE COPED AT THE UPPER PORTION OF THE RAKE TRIM. THE UPPER PORTION OF THE RAKE TRIM WILL NEED TO BE COPED BACK AND BEND UP THE RAKE TRIM INSIDE OF THE CORNER TRIM AS SHOWN. SEAL WITH POLYURETHANE TUBE CAULK (H3152)

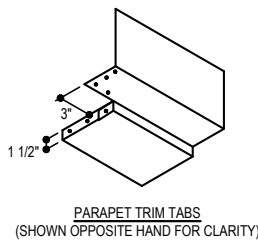
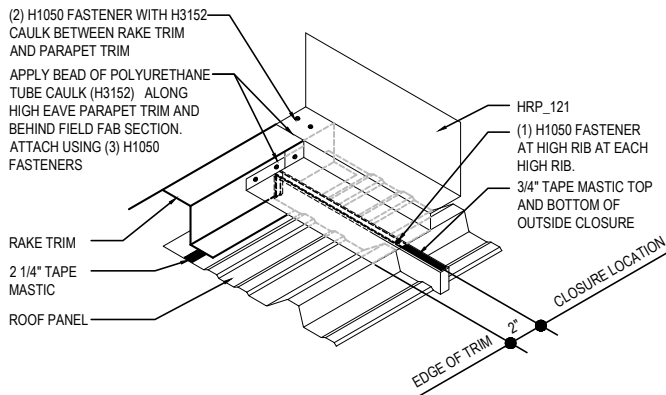
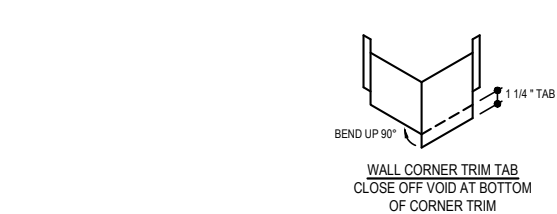
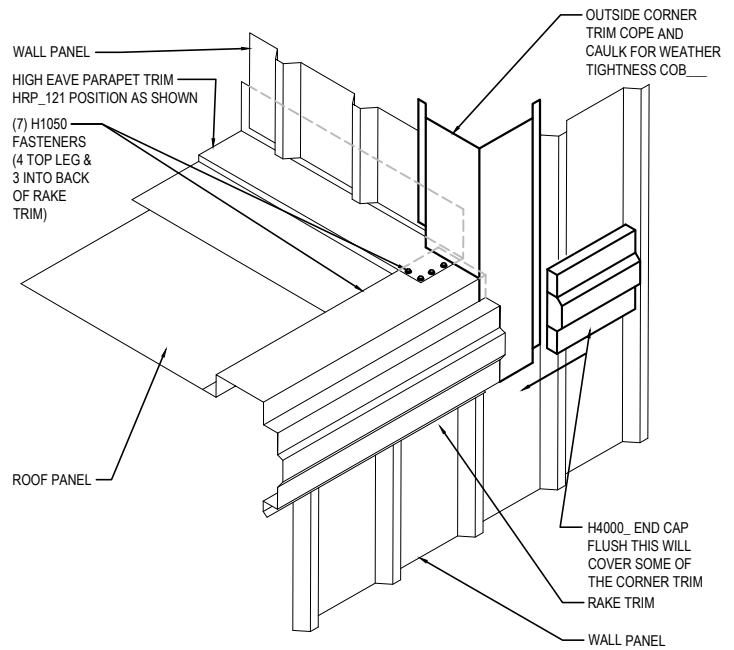

PARAPET TO RAKE TERMINATION

R-PANEL ROOF WITH WALL PANEL
SEE WALL SHEETING ERECTION NOTES FOR WALL PANEL FASTENER LOCATIONS

DI7252

Detailer Notes:

- 1) N/A

DI7281 - HIGH EAVE PARAPET TO RAKE PARAPET - INSIDE

[Download the DWG file by clicking here.](#)

HIGH EAVE PARAPET TO RAKE PARAPET AT CORNER

OUTSIDE CLOSURE AND HIGH EAVE PARAPET TRIM INSTALLATION AND PREPARATION

REFERENCE RAKE AND HIGH EAVE PARAPET DETAILS FOR TYPICAL PARAPET TRIM INSTALLATION.

THE HIGH RAKE PARAPET TRIM SHOULD EXTEND TO THE HIGH EAVE STEEL LINE. THIS WILL ALLOW THE HIGH EAVE PARAPET TRIM TO FORM A CORNER AS SHOWN BELOW.

TEMPORARILY PLACE THE HIGH EAVE PARAPET TRIM (HRP_121) IN POSITION TO DETERMINE THE CORRECT LOCATION OF THE OUTSIDE CLOSURES. THE CLOSURES SHOULD BE 2" AWAY FROM THE LOW END OF THE TRIM AS SHOWN BELOW.

TRIM CLOSURE AT RAKE PARAPET TRIM AND RUN 3/4" TAPE MASTIC (H3000) CONTINUOUSLY FROM BOTTOM OF CLOSURE UP TO TOP TO HELP SECURE CLOSURE TO RAKE AS SHOWN. INSTALL CLOSURES AS YOU PROGRESS.

STOP! FIELD MITERING OF THE HIGH EAVE PARAPET TRIM IS REQUIRED BEFORE INSTALLING. FIELD CUT AND FORM TABS "A", "B", "C" and "D" AS SHOWN BELOW.

NEXT, APPLY A BEAD OF POLYURETHANE TUBE CAULK (H3152) ON TAB "A". PLACE THE HIGH EAVE PARAPET TRIM (HRP_121) OVER THE CLOSURES AND TIGHTLY AGAINST THE RAKE PARAPET TRIM AND FASTEN WITH (3) **TRIM COLORED SELF-DRILLING SCREWS (H1050)**.

APPLY A BEAD OF POLYURETHANE TUBE CAULK (H3152) ON TOP OF RAKE TRIM WHERE HIGH EAVE TRIM WILL BE SEATED.

APPLY A BEAD OF POLYURETHANE TUBE CAULK (H3152) BETWEEN TAB "A" AND TAB "B" AND FASTEN TAB "B" WITH (1) **TRIM COLORED SELF-DRILLING SCREW (H1050)**. NEXT, APPLY A BEAD OF POLYURETHANE TUBE CAULK (H3152) BETWEEN TAB "C" AND TAB "D" AND FASTEN TAB "D" WITH (1) **TRIM COLORED SELF-DRILLING SCREW (H1050)**.

PLACE THE HIGH EAVE PARAPET TRIM (HRP_121) OVER THE CLOSURES AND TIGHTLY AGAINST THE RAKE TRIM AND FASTEN WITH (5) **TRIM COLORED SELF-DRILLING SCREWS (H1050)**.

NEXT, APPLY A BEAD OF POLYURETHANE TUBE CAULK (H3152) WHERE PARAPET TRIMS INTERSECT TO SEAL ANY VOIDS.

NOTE: THE TRIM **MUST** BE PROPERLY POSITIONED BEFORE TOUCHING THE MASTIC. REMOVE PAPER BACKING ONLY AS WORK PROGRESSES. **MASTIC CANNOT BE REUSED.**

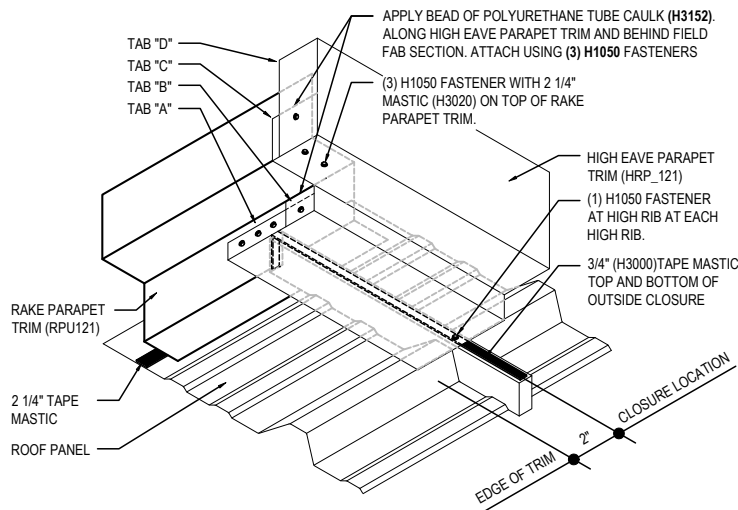

HE PARAPET TO RAKE PARAPET INSIDE CORNER

DETAIL SHOWN WITH ROOF AND WALL PANEL.
SEE WALL SHEETING ERECTION NOTES FOR WALL PANEL FASTENER LOCATIONS

DI7281

Detailer Notes:

1) N/A

DI7282 HIGH EAVE PARAPET WITH RAKE TERMINATION - INSIDE

[Download the DWG file by clicking here.](#)

HIGH EAVE PARAPET WITH RAKE TERMINATION AT CORNER

**RAKE TERMINATION AT WALL
STEP 1**

EXTEND THE RAKE TRIM TO STEEL LINE WHERE THE PROFILE WILL BE MITERED FLUSH WITH THE WALL. ATTACH THE RAKE TRIM END CAP (H4000_) AND RAKE END CAP (RTSC) INTO THE HIGH SIDE OF THE RAKE TRIM. FASTEN WITH POP RIVETS (H1100).

**OUTSIDE CLOSURE INSTALLATION AND PREPARATION
STEP 2**

TEMPORARILY PLACE THE HIGH EAVE PARAPET TRIM IN POSITION TO DETERMINE THE CORRECT LOCATION OF THE OUTSIDE CLOSURES. THE CLOSURES SHOULD BE 2" AWAY FROM THE LOW END OF THE TRIM AS SHOWN.

CUT OUTSIDE CLOSURE TO FIT BACK OF RAKE TRIM AND RUN 3/4" TAPE MASTIC (H3000) CONTINUOUSLY BOTTOM AND TOP OF CLOSURE AND BETWEEN RAKE TRIM AS SHOWN.

**HIGH EAVE PARAPET TRIM INSTALLATION
STEP 3**

REFERENCE HIGH EAVE PARAPET DETAIL FOR TYPICAL PARAPET INSTALLATION. THE HIGH EAVE PARAPET TRIM SHOULD EXTEND ALL THE WAY OVER TO THE EDGE OF THE TOP HORIZONTAL LEG OF THE RAKE TRIM AS SHOWN. THE LOWER PORTION OF PARAPET TRIM WILL TERMINATE INTO BACK OF RAKE TRIM. BEND AND TAB AS SHOWN. USE POLYURETHANE TUBE CAULK (H3152) AND FASTEN THE PARAPET TRIM TO RAKE TRIM WITH (H1050) FASTENERS.

**WALL PANEL INSTALLATION (SEE OPTION 1 BELOW)
STEP 4**

INSTALL WALL PANEL ACCORDING THOSE DETAILS. SEAL ANY VOIDS WITH POLYURETHANE TUBE CAULK (H3152)

**WALL BY OTHERS (SEE OPTION 2 BELOW)
STEP 4**

REFERENCE PARAPET TRIM TO WALL BY OTHERS DETAIL. COUNTER FLASHING NOT SUPPLIED BY M.B.S.

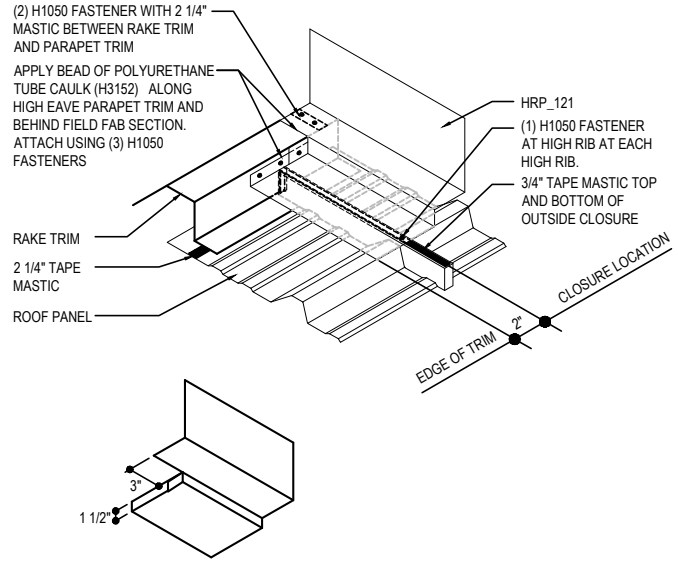

**PARAPET AND RAKE TERMINATION WALL PANEL
STEP 2 (OPTION 1)**

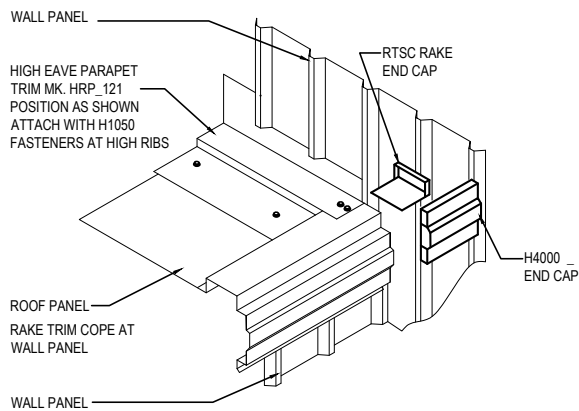

**PARAPET AND RAKE TERMINATION WALL BY OTHERS
STEP 2 (OPTION 2)**

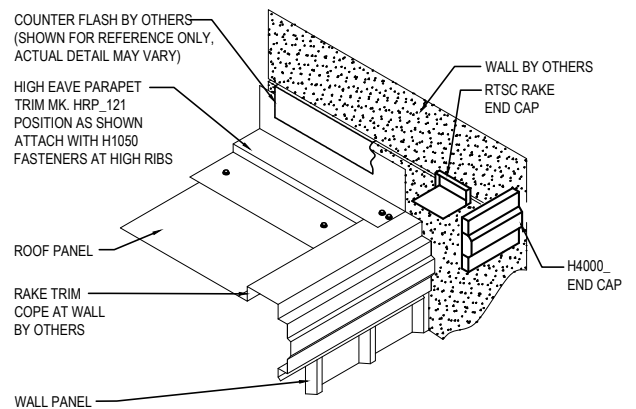

PARAPET TO RAKE TERMINATION

R-PANEL ROOF WITH WALL PANEL
SEE WALL SHEETING ERECTION NOTES FOR WALL PANEL FASTENER LOCATIONS

DI7282

Detailer Notes:

1) N/A