

**LOW EAVE (BASIC)**

EB7005 - NBS - LOW EAVE INSIDE CORNER

EB7021 - LOW EAVE BASIC TO RAKE PARAPET

EB7022 - SCULPTURED RAKE TO BASIC LOW EAVE

EB7023 - RAKE EXTENSION SPACER CAP INSTALLATION

EB7005 LOW EAVE INSIDE CORNER TERMINATION

[Download the DWG file by clicking here.](#)

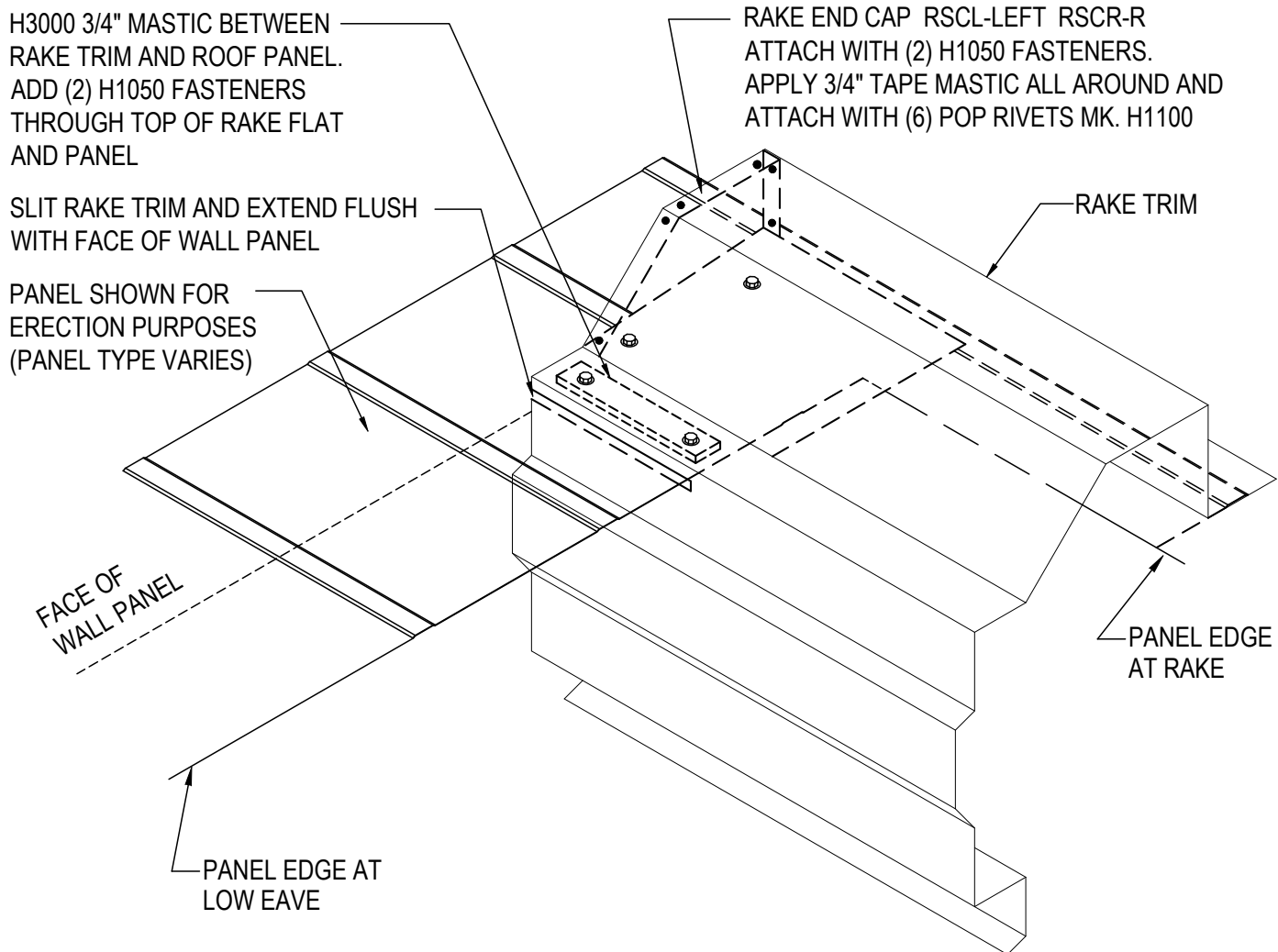

**LOW EAVE INSIDE CORNER DETAIL**

USE THIS DETAIL ON ALL BUILDINGS WITH SCULPTURED RAKE TRIM.  
WHEN USING SCULPTURED EAVE TRIM, MITRE TO FIT RAKE TRIM.

**EB7005**

Detailer Notes:

- 1) THIS DETAIL IS DUPLICATE OF DB7005. DUPLICATE DETAILS ARE TO ENSURE THAT THEY ARE PLACED IN ORDER IN ERECTION DRAWINGS.

EB7021 LOW EAVE BASIC TO RAKE PARAPET

[Download the DWG file by clicking here.](#)

RAKE PARAPET TRIM INSTALLATION

DRY FIT RAKE PARAPET CAP FOR POSITION ON PANEL. NOTCH BOTTOM OF CAP FOR RAKE ANGLE AS NEEDED. FASTEN WITH (3) H1050 FASTENERS, (2) INTO EAVE PLATE AND (1) AT EDGE OF PANEL AS SHOWN BELOW.

APPLY 3/4" TAPE MASTIC (H3000) AROUND THE PERIMETER OF THE RAKE PARAPET CAP AS SHOWN.

PARAPET TRIM SHOULD EXTEND TO END OF ROOF PANEL AS SHOWN. INSTALL PARAPET TRIM AS INDICATED IN THE PARAPET TRIM DETAIL. ALL PARTS MUST BE POSITIONS PROPERLY BEFORE TOUCHING THE MASTIC TO ROOF PANEL AND TRIM. MASTIC CANNOT BE REUSED! PEEL PAPER OFF MASTIC ONLY AS WORK PROGRESSES.

IF YOUR BUILDING HAS A GUTTER, SEE THE GUTTER DETAIL FOR GUTTER END CAP INSTALLATION. HOLD GUTTER JUST SHORT OF EXTENDED WALL AS REQUIRED.

RAKE PARAPET CAP PART NUMBERS  
• RPCL (LEFT) • RPCR (RIGHT)

RAKE PARAPET TRIM  
• RPU121

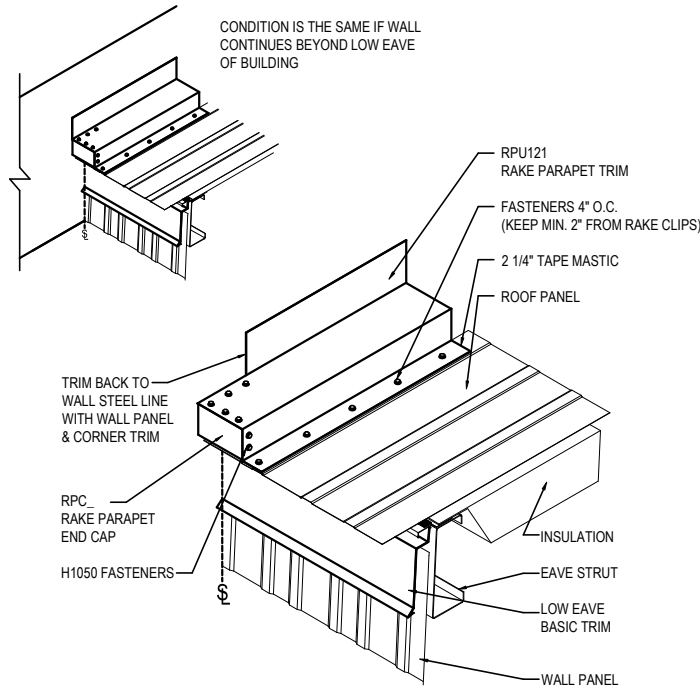
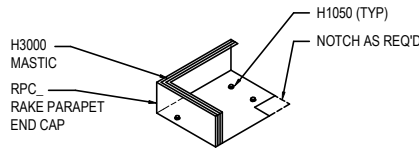

NOTE: ALL POP RIVETS AND FASTENERS ARE TO BE SET "IN" THE MASTIC OR CAULK

UNIVERSAL CORNER TO PARAPET

DETAIL SHOWN WITH WALL PANEL WITHOUT GUTTER FOR CLARITY. BASIC LOW EAVE IS SHOWN. INSTALLATION OF MASONRY AND INSULATED WALL PANEL CONDITIONS SIMILAR.

**EB7021**

Detailer Notes:

- 1) THIS DETAIL IS DUPLICATE OF DB7021, DD7021, AND ED7021. DUPLICATE DETAILS ARE TO ENSURE THAT THEY ARE PLACED IN ORDER IN ERECTION DRAWINGS.

EB7022 - SCULPTURED RAKE TO BASIC LOW EAVE

[Download the DWG file by clicking here.](#)

**STEP 1**

**PREPARATION FOR RAKE TRIM INSTALLATION AT BUILDING WITHOUT GUTTER**

**END CAP ASSEMBLY**

ASSEMBLE THE RAKE CAP END (RSCE) TO THE GUTTER END CAP (H4000\_) WITH (6) POP RIVETS (H1100) AS SHOWN.

**RAKE CAP PART NUMBERS**

• RTSC

APPLY POLYURETHANE TUBE CAULK (H3152) TO (3) SIDES OF THE RTSC AND PLACE IT ON THE END OF THE PANEL. HOLD THE END CAP ASSEMBLY AGAINST THE CORNER TRIM TO ALIGN THE RAKE CAP TO THE BACK OF THIS ASSEMBLY. USE (1) H1030 FASTENER FOR THE RAKE CAP TO EAVE PLATE. FIELD COPE FLAT OF RTSC AS REQUIRED TO FIT AROUND THE RAKE ANGLE.

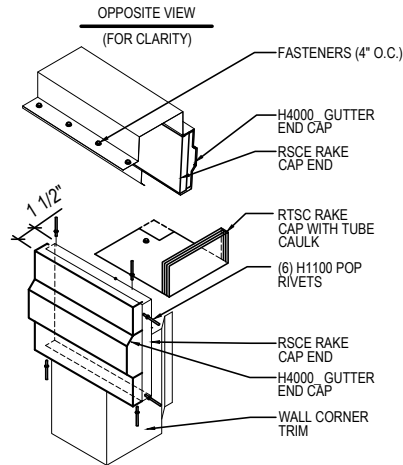

**STEP 2**

**RAKE TRIM INSTALLATION AT BUILDING WITHOUT GUTTER**

APPLY POLYURETHANE TUBE CAULK (H3152) TO THE OUTSIDE PERIMETER OF THE END CAP ASSEMBLY RSCE & H4000\_ AND PLACE IT INSIDE THE RAKE TRIM WITH THE FLAT EDGE OF THE GUTTER END CAP FLUSH WITH THE END OF THE RAKE TRIM. FASTEN WITH POP RIVETS (H1100).

**RAKE TRIM PART NUMBERS**

• RTS\_121 X 10'-1"      • RTS\_242 X 20'-2"

EXTEND THE LOW EAVE END OF THE RAKE TRIM FLUSH WITH THE LOW EAVE END OF THE ROOF PANEL. FASTEN THE RAKE TRIM TO THE ROOF PANEL AS INDICATED IN THE RAKE TRIM DETAIL.

COPE THE BOTTOM VERTICAL LEG OF THE RAKE TRIM FLUSH WITH THE OUTSIDE EDGE OF THE WALL CORNER TRIM.

ALWAYS START THE RAKE TRIM INSTALLATION AT THE LOW EAVE WORKING TOWARD THE HIGH EAVE OR RIDGE.

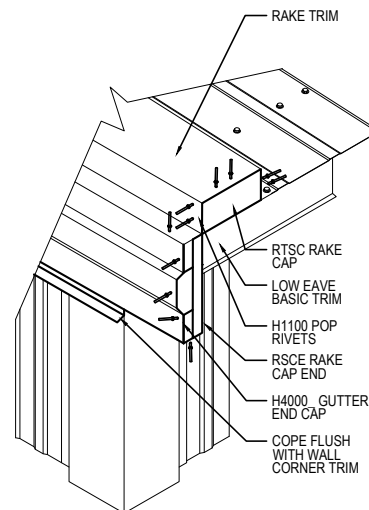

**SCULPTURED RAKE TO BASIC LOW EAVE**

DETAIL SHOWN WITH WALL PANEL AND CORNER TRIM. MASONRY AND INSULATED WALL PANEL CONDITIONS SIMILAR.

**EB7022**

**Detailer Notes:**

- 1) THIS DETAIL IS DUPLICATE OF DB7022. DUPLICATE DETAILS ARE TO ENSURE THAT THEY ARE PLACED IN ORDER IN ERECTION DRAWINGS.

EB7023 - RAKE EXTENSION SPACER CAP INSTALLATION

[Download the DWG file by clicking here.](#)

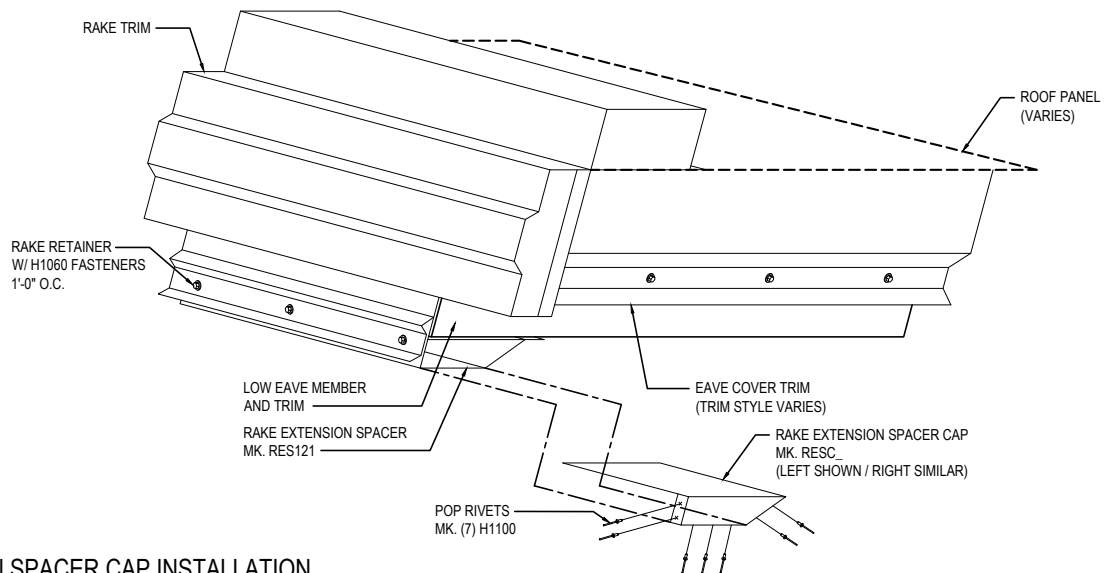

RAKE EXTENSION SPACER CAP INSTALLATION

EB7023

Detailer Notes:

- 1) THIS CED IS A DUPLICATE OF DB7023.