

**RAKE (SCULPTURED)**

EE3011 - SCULPTURED RAKE W/ WALL PANEL

EE3041 - SCULPTURED RAKE W/ MASONRY WALL

EE3061 - SCULPTURED RAKE W/ OPEN WALL AND NO LINER PANEL  
(BYPASS ENDWALL)

EE3062 - SCULPTURED RAKE W/ OPEN WALL AND LINER PANEL (BYPASS ENDWALL)

EE3063 - SCULPTURED RAKE W/ OPEN WALL AND NO LINER PANEL  
(INSET / FLUSH ENDWALL)

EE3064 - SCULPTURED RAKE W/ OPEN WALL AND LINER PANEL  
(INSET / FLUSH ENDWALL)

EE3081 - SCULPTURED RAKE W/ OPEN WALL (JOIST)

EE3611 - SCULPTURED RAKE W/ INSULATED WALL PANEL

EE3901 - SCULPTURED RAKE TO RAKE PARAPET TRANSITION

---

EE3011 - SCULPTURED RAKE W/ WALL PANEL

[Download the DWG file by clicking here.](#)

**RAKE LAP & FLASHING BACKER**

SLIDE FIELD CUT SECTION OF FLASHING ENDLAP BACKER ONTO THE LOWER TRIM PIECE AS SHOWN BELOW. PLACE TAPE MASTIC NEXT TO HEM OF THE BACKER (NOT ON TOP OF HEM). APPLY CONTINUOUS BEAD OF CAULK 1" FROM END OF TRIM DOWN PROFILE OF TRIM. FASTEN LAP WITH STITCH FASTENERS AND POP RIVETS AS SHOWN. ROOF STRUCTURAL FASTENERS SHOULD BE USED TO FASTEN THROUGH PANEL FLAT INTO RAKE ANGLE.

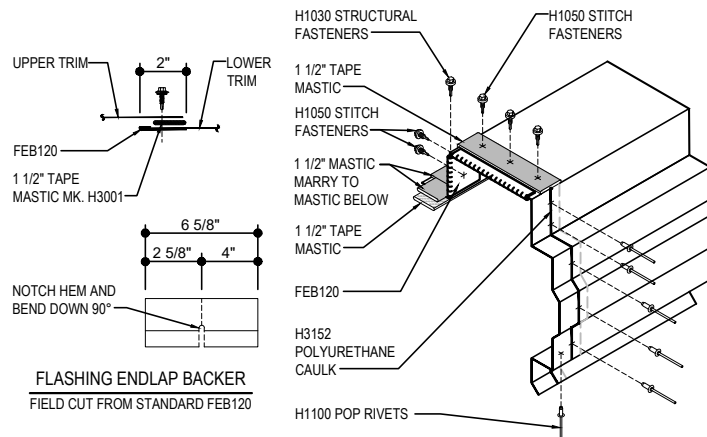

**NOTE 1: KEEP FASTENERS 2 1/2" AWAY FROM RAKE CLIPS!!**  
**REFERENCE DETAIL EA3076 FOR ADDITIONAL REQUIRED TRIM LAP FASTENER**

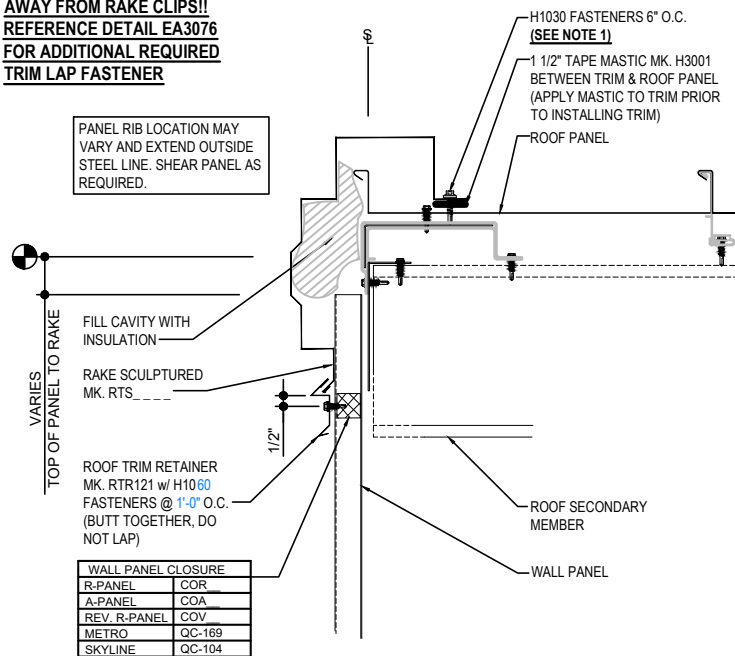

**SCULPTURED RAKE W/ WALL PANEL**

VERTICAL RIB ROOF PANEL  
SEE WALL SHEETING ERECTION NOTES FOR WALL PANEL FASTENER LOCATIONS

**EE3011**

**Detailer Notes:**

- 1) CLOSURES RAKE LAYER DEFAULT IS ON. LAYER MUST BE TURNED OFF IF CLOSURES ARE NOT REQUIRED.

EE3041 - SCULPTURED RAKE W/ MASONRY WALL

[Download the DWG file by clicking here.](#)

**RAKE LAP & FLASHING BACKER**

SLIDE FIELD CUT SECTION OF FLASHING ENDLAP BACKER ONTO THE LOWER TRIM PIECE AS SHOWN BELOW. PLACE TAPE MASTIC NEXT TO HEM OF THE BACKER (NOT ON TOP OF HEM). APPLY CONTINUOUS BEAD OF CAULK 1" FROM END OF TRIM DOWN PROFILE OF TRIM. FASTEN LAP WITH STITCH FASTENERS AND POP RIVETS AS SHOWN. ROOF STRUCTURAL FASTENERS SHOULD BE USED TO FASTEN THROUGH PANEL FLAT INTO RAKE ANGLE.

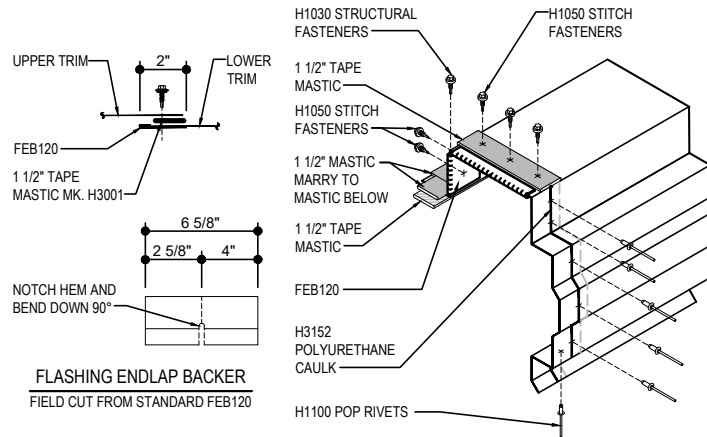

**NOTE 1: KEEP FASTENERS 2 1/2" AWAY FROM RAKE CLIPS!!**  
**REFERENCE DETAIL EA3076 FOR ADDITIONAL REQUIRED TRIM LAP FASTENER**

PANEL RIB LOCATION MAY VARY AND EXTEND OUTSIDE STEEL LINE. SHEAR PANEL AS REQUIRED.

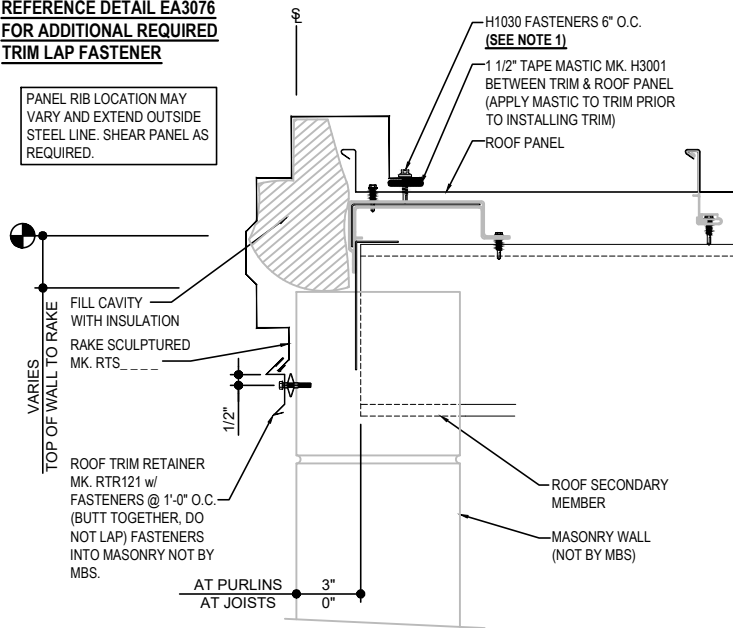

**SCULPTURED RAKE W/ MASONRY WALL**  
VERTICAL RIB ROOF PANEL

EE3041

Detailer Notes:

- 1) N/A

EE3061 - SCULPTURED RAKE W/ OPEN WALL AND NO LINER PANEL (BYPASS ENDWALL)

[Download the DWG file by clicking here.](#)

**RAKE LAP & FLASHING BACKER**

SLIDE FIELD CUT SECTION OF FLASHING ENDLAP BACKER ONTO THE LOWER TRIM PIECE AS SHOWN BELOW. PLACE TAPE MASTIC NEXT TO HEM OF THE BACKER (NOT ON TOP OF HEM). APPLY CONTINUOUS BEAD OF CAULK 1" FROM END OF TRIM DOWN PROFILE OF TRIM. FASTEN LAP WITH STITCH FASTENERS AND POP RIVETS AS SHOWN. ROOF STRUCTURAL FASTENERS SHOULD BE USED TO FASTEN THROUGH PANEL FLAT INTO RAKE ANGLE.

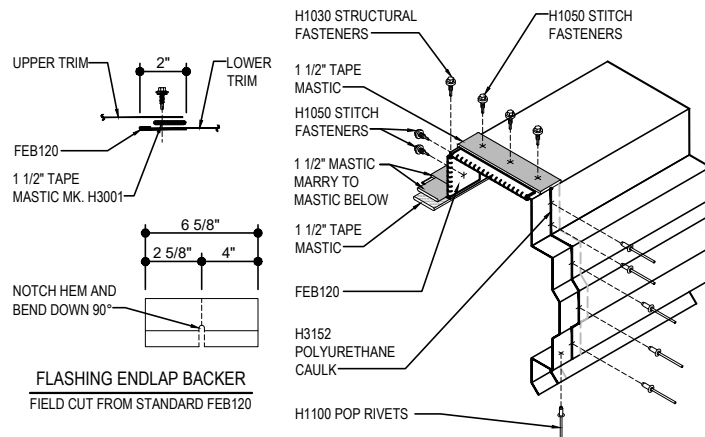

**NOTE 1: KEEP FASTENERS 2 1/2" AWAY FROM RAKE CLIPS!!**  
**REFERENCE DETAIL EA3076 FOR ADDITIONAL REQUIRED TRIM LAP FASTENER**

PANEL RIB LOCATION MAY VARY AND EXTEND OUTSIDE STEEL LINE. SHEAR PANEL AS REQUIRED.

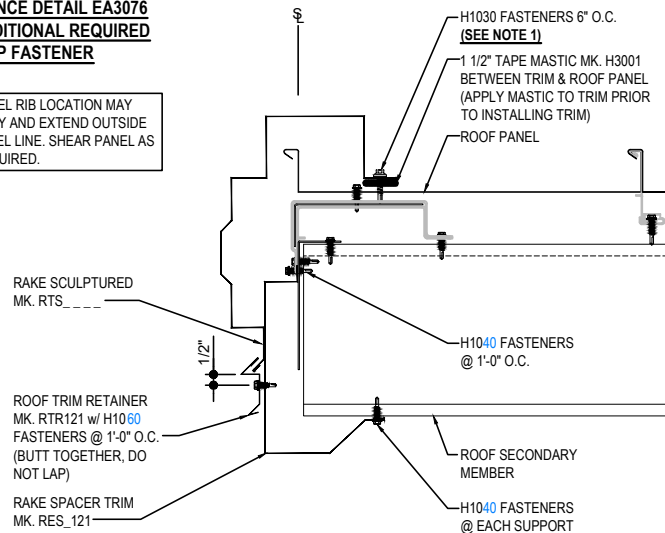

**SCULPTURED RAKE W/ OPEN WALL AND NO LINER PANEL (BYPASS ENDWALL)**

VERTICAL RIB ROOF PANEL

EE3061

**Detailer Notes:**

- 1) DETAIL CAN BE USED WITH PARTIALLY SHEETED WALLS AND FULLY OPEN WALLS.
- 2) DETAIL APPLIES TO THE MAIN BUILDING RAKE LINE. SEE EAVE/RAKE EXTENSION OR CANOPY SHEETING SECTIONS FOR OTHER SOFFIT/LINER CONFIGURATIONS.

EE3062 - SCULPTURED RAKE W/ OPEN WALL AND LINER PANEL (BYPASS ENDWALL)

[Download the DWG file by clicking here.](#)

**RAKE LAP & FLASHING BACKER**

SLIDE FIELD CUT SECTION OF FLASHING ENDLAP BACKER ONTO THE LOWER TRIM PIECE AS SHOWN BELOW. PLACE TAPE MASTIC NEXT TO HEM OF THE BACKER (NOT ON TOP OF HEM). APPLY CONTINUOUS BEAD OF CAULK 1" FROM END OF TRIM DOWN PROFILE OF TRIM. FASTEN LAP WITH STITCH FASTENERS AND POP RIVETS AS SHOWN. ROOF STRUCTURAL FASTENERS SHOULD BE USED TO FASTEN THROUGH PANEL FLAT INTO RAKE ANGLE.

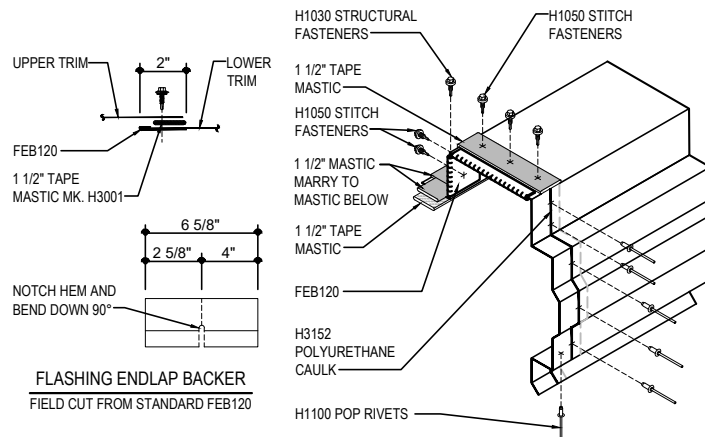

**NOTE 1: KEEP FASTENERS 2 1/2" AWAY FROM RAKE CLIPS!!**  
**REFERENCE DETAIL EA3076 FOR ADDITIONAL REQUIRED TRIM LAP FASTENER**

PANEL RIB LOCATION MAY VARY AND EXTEND OUTSIDE STEEL LINE. SHEAR PANEL AS REQUIRED.

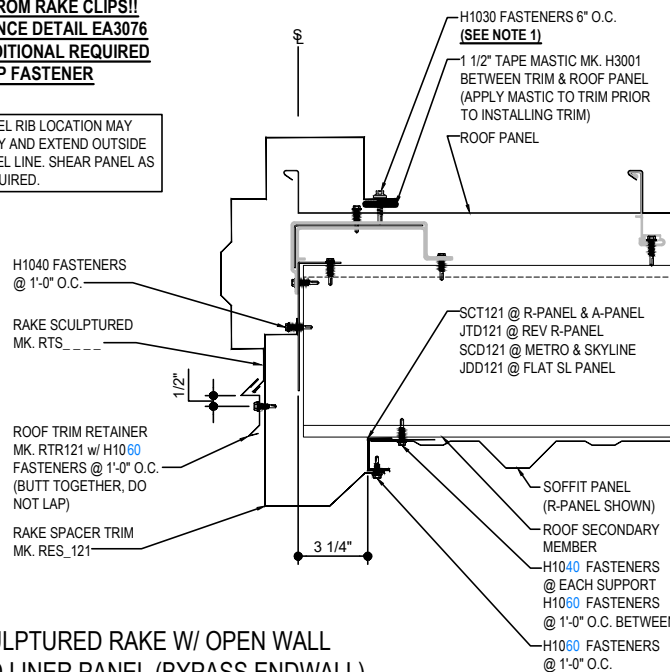

**SCULPTURED RAKE W/ OPEN WALL AND LINER PANEL (BYPASS ENDWALL)**

VERTICAL RIB ROOF PANEL

**EE3062**

**Detailer Notes:**

- 1) DETAIL CAN BE USED WITH PARTIALLY SHEETED WALLS AND FULLY OPEN WALLS.
- 2) DETAIL APPLIES TO THE MAIN BUILDING RAKE LINE. SEE EAVE/RAKE EXTENSION OR CANOPY SHEETING SECTIONS FOR OTHER SOFFIT/LINER CONFIGURATIONS.
- 3) USE "NBG LINER FRAME" SMART KIT FOR TRIM AT RAFTER.

EE3063 - SCULPTURED RAKE W/ OPEN WALL AND NO LINER PANEL (INSET / FLUSH ENDWALL)

[Download the DWG file by clicking here.](#)

**RAKE LAP & FLASHING BACKER**

SLIDE FIELD CUT SECTION OF FLASHING ENDLAP BACKER ONTO THE LOWER TRIM PIECE AS SHOWN BELOW. PLACE TAPE MASTIC NEXT TO HEM OF THE BACKER (NOT ON TOP OF HEM). APPLY CONTINUOUS BEAD OF CAULK 1" FROM END OF TRIM DOWN PROFILE OF TRIM. FASTEN LAP WITH STITCH FASTENERS AND POP RIVETS AS SHOWN. ROOF STRUCTURAL FASTENERS SHOULD BE USED TO FASTEN THROUGH PANEL FLAT INTO RAKE ANGLE.

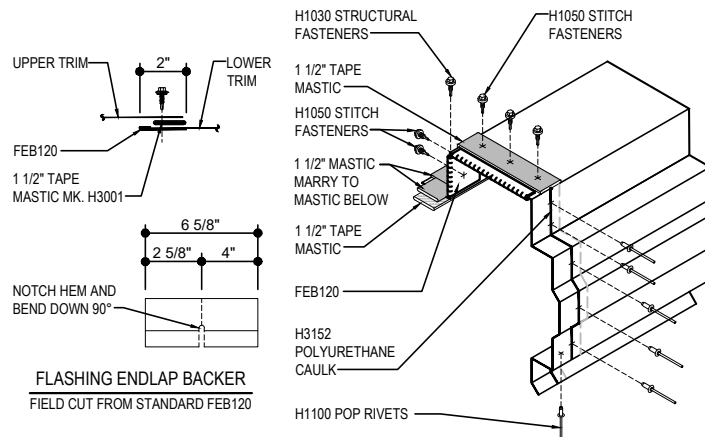

**NOTE 1: KEEP FASTENERS 2 1/2" AWAY FROM RAKE CLIPS!!**  
**REFERENCE DETAIL EA3076 FOR ADDITIONAL REQUIRED TRIM LAP FASTENER**

PANEL RIB LOCATION MAY VARY AND EXTEND OUTSIDE STEEL LINE. SHEAR PANEL AS REQUIRED.

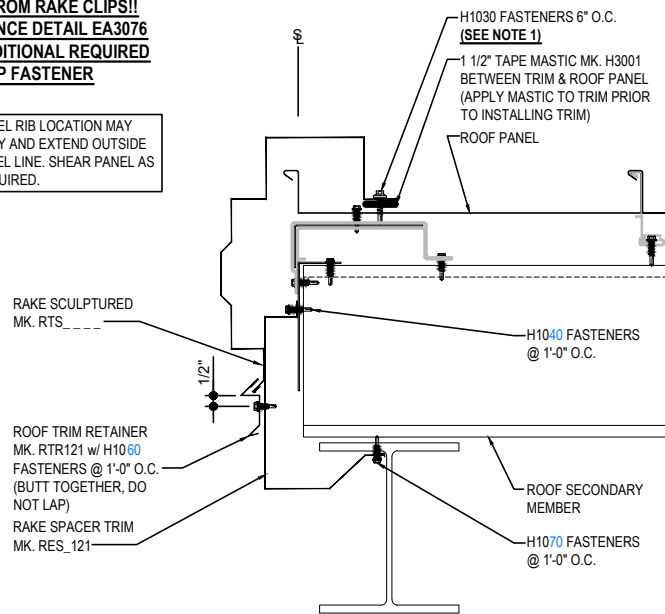

**SCULPTURED RAKE W/ OPEN WALL AND NO LINER PANEL (INSET / FLUSH ENDWALL)**

VERTICAL RIB ROOF PANEL

**EE3063**

**Detailer Notes:**

- 1) DETAIL CAN BE USED WITH PARTIALLY SHEETED WALLS AND FULLY OPEN WALLS.
- 2) DETAIL APPLIES TO THE MAIN BUILDING RAKE LINE. SEE EAVE/RAKE EXTENSION OR CANOPY SHEETING SECTIONS FOR OTHER SOFFIT/LINER CONFIGURATIONS.

EE3064 - SCULPTURED RAKE W/ OPEN WALL AND LINER PANEL (INSET / FLUSH ENDWALL)

[Download the DWG file by clicking here.](#)

**RAKE LAP & FLASHING BACKER**

SLIDE FIELD CUT SECTION OF FLASHING ENDLAP BACKER ONTO THE LOWER TRIM PIECE AS SHOWN BELOW. PLACE TAPE MASTIC NEXT TO HEM OF THE BACKER (NOT ON TOP OF HEM). APPLY CONTINUOUS BEAD OF CAULK 1" FROM END OF TRIM DOWN PROFILE OF TRIM. FASTEN LAP WITH STITCH FASTENERS AND POP RIVETS AS SHOWN. ROOF STRUCTURAL FASTENERS SHOULD BE USED TO FASTEN THROUGH PANEL FLAT INTO RAKE ANGLE.

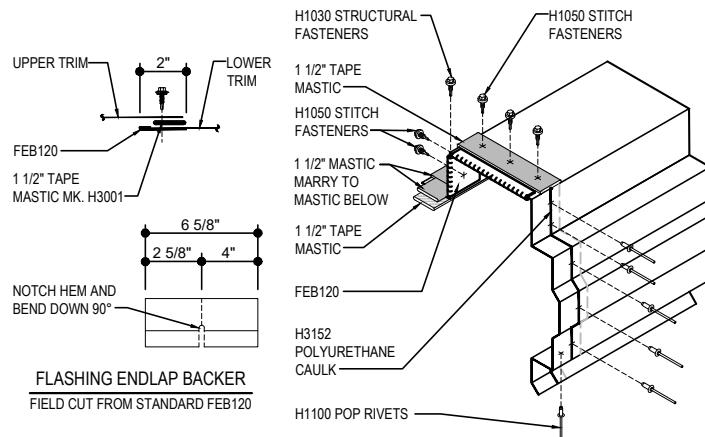

**NOTE 1: KEEP FASTENERS 2 1/2" AWAY FROM RAKE CLIPS!!**  
**REFERENCE DETAIL EA3076 FOR ADDITIONAL REQUIRED TRIM LAP FASTENER**

PANEL RIB LOCATION MAY VARY AND EXTEND OUTSIDE STEEL LINE. SHEAR PANEL AS REQUIRED.

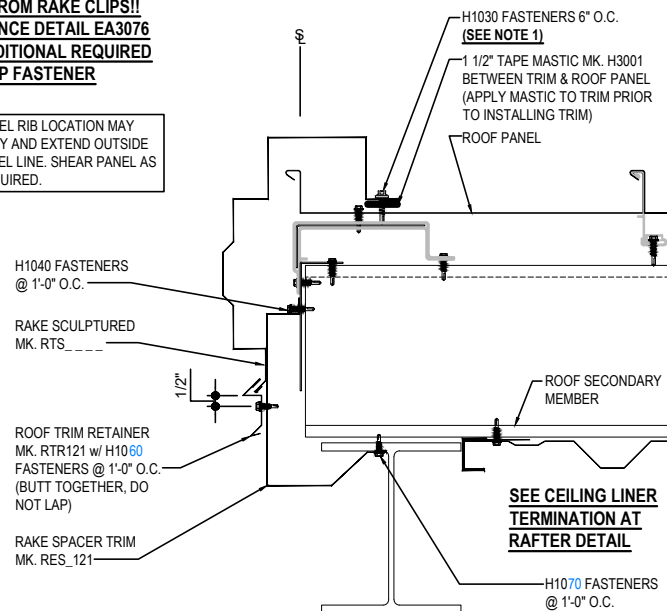

**SCULPTURED RAKE W/ OPEN WALL AND LINER PANEL (INSET / FLUSH ENDWALL)**

VERTICAL RIB ROOF PANEL

EE3064

**Detailer Notes:**

- 1) DETAIL CAN BE USED WITH PARTIALLY SHEETED WALLS AND FULLY OPEN WALLS.
- 2) DETAIL APPLIES TO THE MAIN BUILDING RAKE LINE. SEE EAVE/RAKE EXTENSION OR CANOPY SHEETING SECTIONS FOR OTHER SOFFIT/LINER CONFIGURATIONS.
- 3) USE "NBG LINER FRAME" SMART KIT FOR TRIM AT RAFTER.



EE3611 - SCULPTURED RAKE W/ INSULATED WALL PANEL

[Download the DWG file by clicking here.](#)

**RAKE LAP & FLASHING BACKER**

SLIDE FIELD CUT SECTION OF FLASHING ENDLAP BACKER ONTO THE LOWER TRIM PIECE AS SHOWN BELOW. PLACE TAPE MASTIC NEXT TO HEM OF THE BACKER (NOT ON TOP OF HEM). APPLY CONTINUOUS BEAD OF CAULK 1" FROM END OF TRIM DOWN PROFILE OF TRIM. FASTEN LAP WITH STITCH FASTENERS AND POP RIVETS AS SHOWN. ROOF STRUCTURAL FASTENERS SHOULD BE USED TO FASTEN THROUGH PANEL FLAT INTO RAKE ANGLE.

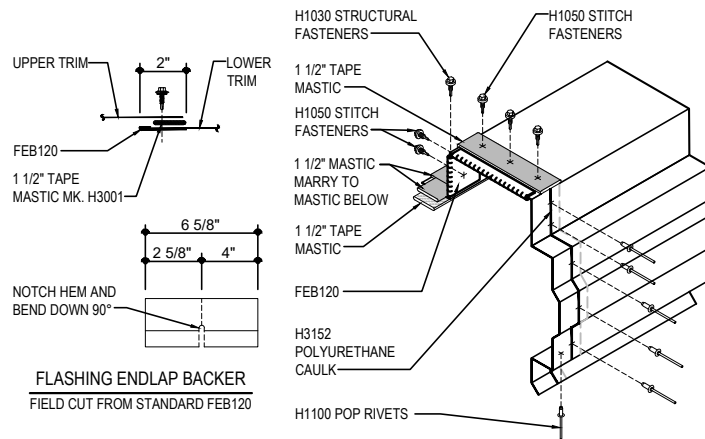

**NOTE 1: KEEP FASTENERS 2 1/2" AWAY FROM RAKE CLIPS!!**  
**REFERENCE DETAIL EA3076 FOR ADDITIONAL REQUIRED TRIM LAP FASTENER**

**TRIM LAP FASTENER**

ROOF PANEL SETBACK		
▲ THICKNESS	" SETBACK	NOTE
2"	0"	POSITIVE SETBACK DIM. IS OUTSIDE STEEL LINE
2 1/2"	0"	
3"	0"	
4"	1"	

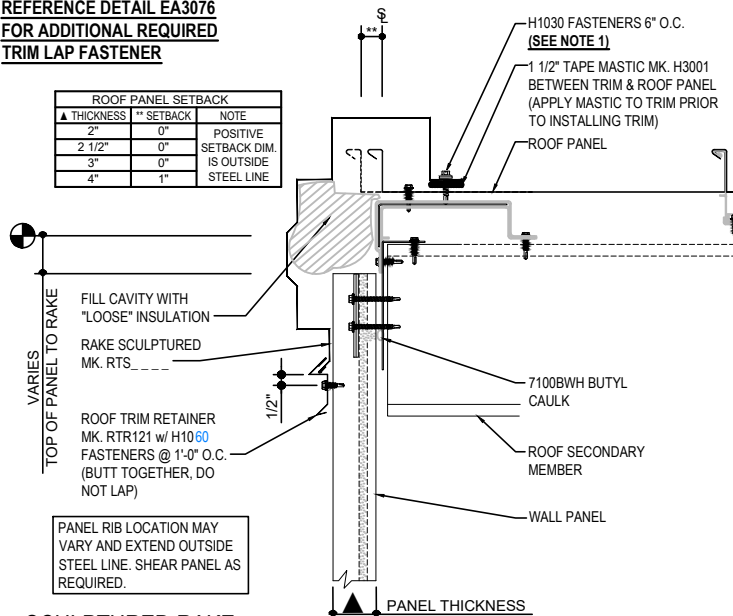

**SCULPTURED RAKE W/ INSULATED WALL PANEL**

VERTICAL RIB ROOF PANEL  
SEE WALL SHEETING ERECTION NOTES FOR WALL PANEL FASTENER LOCATIONS

**EE3611**

Detailer Notes:

- 1) N/A

**EE3901 - SCULPTURED RAKE TO RAKE PARAPET TRANSITION**

Download the DWG file by clicking [here](#).

**RAKE TRIM PREP**

**END CAP ASSEMBLY**

ASSEMBLE THE RAKE CAP END (RSCE) TO THE GUTTER END CAP (H4000\_) WITH (6) POP RIVETS (H1100) AS SHOWN.

**RAKE CAP PART NUMBERS**

• RTSC

**RAKE TRIM PART NUMBERS**

• RTS\_121 X 10'-1" • RTS\_242 X 20'-2"

APPLY POLYURETHANE TUBE CAULK (H3152) TO (3) SIDES OF THE RTSC AND PLACE CAP FLUSH WITH THE END OF THE RAKE TRIM. FASTEN WITH (6) POP RIVETS (H1100) AS SHOWN.

APPLY POLYURETHANE TUBE CAULK (H3152) TO THE OUTSIDE PERIMETER OF THE END CAP ASSEMBLY RSCE & H4000\_ AND PLACE IT INSIDE THE RAKE TRIM WITH THE FLAT EDGE OF THE GUTTER END CAP FLUSH WITH THE END OF THE RAKE TRIM. FASTEN WITH POP RIVETS (H1100).

FASTEN THE RAKE TRIM TO THE ROOF PANEL AS INDICATED IN THE RAKE TRIM DETAIL.

ALWAYS START THE RAKE TRIM INSTALLATION AT THE LOW EAVE WORKING TOWARD THE HIGH EAVE OR RIDGE.

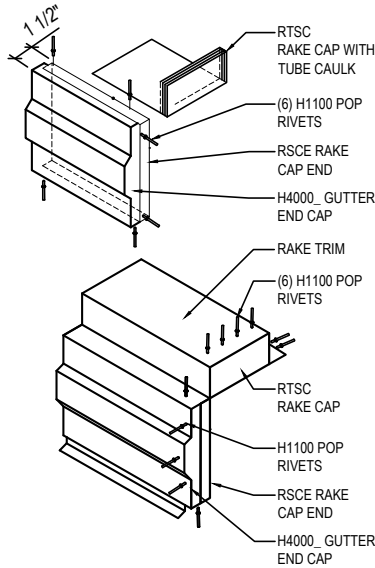

**LAPPING RAKE TRIM TO PARAPET TRIM**

NOTE:  
RAKE PARAPET ON HIGH SIDE OF ROOF SLOPE SHOWN.  
SCULPTURED RAKE ON HIGH SIDE IS SIMILAR.

\*\*\* ALWAYS INSTALL UPHILL TRIM CAP 2" INSIDE OF TRIM TO ALLOW FOR A 2" TRIM LAP.



**ASSEMBLY VIEW**

**RAKE PARAPET PREP**

NOTE: ALL POP RIVETS AND FASTENERS ARE TO BE SET "IN" THE CAULK

**RAKE PARAPET CAP PART NUMBERS**

• RPCL (LEFT) • RPCR (RIGHT)

**RAKE PARAPET TRIM PART NUMBER**

• PRT121

FIELD NOTCH / TAB RPCR/L TO FIT INSIDE OF PRT121 PARAPET RAKE TRIM.

APPLY POLYURETHANE TUBE CAULK (H3152) AROUND THE PERIMETER OF THE RPCR/L AND PLACE CAP FLUSH WITH THE END OF THE PARAPET TRIM. FASTEN WITH (7) FASTENERS (H1050) AS SHOWN.

FASTEN PARAPET TRIM TO THE ROOF PANEL AS INDICATED IN THE PARAPET TRIM DETAIL.

ALWAYS START THE PARAPET TRIM INSTALLATION AT THE LOW EAVE WORKING TOWARD THE HIGH EAVE OR RIDGE.

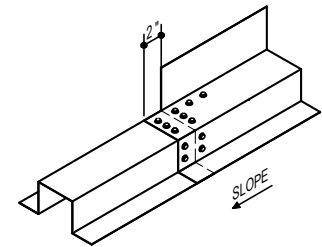
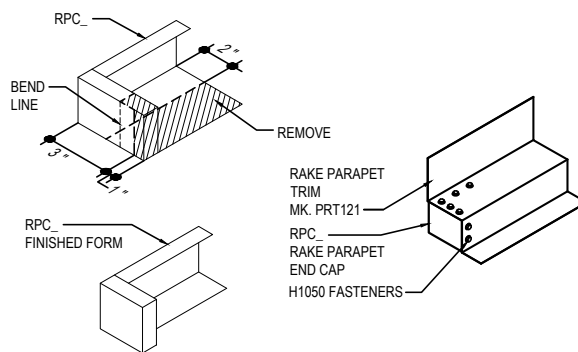

**FINISHED VIEW**

**ISOMETRIC VIEW**

TRIMS ALONG RAKE COULD TRANSITION FROM RAKE TRIM TO RAKE PARAPET OR FROM RAKE PARAPET TO RAKE TRIM, STARTING AT LOW EAVE WORKING TOWARD THE HIGH EAVE OR RIDGE.

TRIM END CAP PARTS AND ATTACHMENTS ARE SUPPLIED SPECIFICALLY TO EITHER OF THESE TWO TRANSITION CONDITIONS, IF PROJECT REQUIRES.

TRIM PROFILES MAY BE INSTALLED OPPOSITE OF WHAT IS SHOWN, INSTALLATION OF END CAPS INTO TRIM ARE THE SAME.

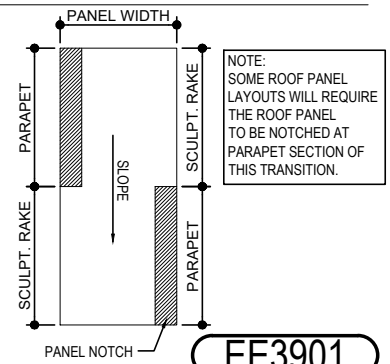
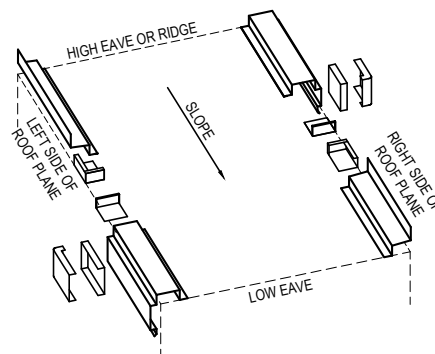

**EE3901**

**SCULPTURED RAKE TO RAKE PARAPET TRANSITION**

**Detailer Notes:**

1) THIS DETAIL IS DUPLICATE OF DE6901 AND EE6901. DUPLICATE DETAILS ARE TO ENSURE THAT THEY ARE PLACED IN ORDER IN ERECTION DRAWINGS.