

CONSTRUCTION JOINT

EJ7030-CONSTRUCTION JOINT END CAP - CONTINUOUS

EJ7036-CONSTRUCTION JOINT END CAP - OFFSET

EJ7037-CONSTRUCTION JOINT TERMINATION - HE & RIDGE

EXPANSION JOINT

EJ7040-EXPANSION JOINT END CAP - CONTINUOUS

EJ7044-EXPANSION JOINT END CAP - OFFSET

EJ7046-EXPANSION JOINT SPLICE

EJ7047-EXPANSION JOINT TERMINATION - RIDGE

EJ7048-EXPANSION JOINT TERMINATION - HE PARAPET

EJ7049-EXPANSION JOINT TERMINATION - HE SCULPTURED

EJ7050-EXPANSION JOINT TERMINATION - ROOF STEP

ROOF STEP

EJ7150-ROOF STEP TERMINATION

EJ7030 - CONSTRUCTION JOINT END CAP - CONTINUOUS

[Download the DWG file by clicking here.](#)

INSTALLATION NOTES

INSTALL THE CONSTRUCTION JOINT SUPPORT AND ZEE MEMBERS AS INDICATED IN THE CONSTRUCTION JOINT DETAIL. MAKE SURE THAT THE MASTIC OVER THE EAVE PLATE AND UNDER THE ROOF PANEL RUN CONTINUOUS THROUGH THE JOINT AREA. IF NOT, ADD MASTIC ACROSS EAVE PLATE.

INSTALL END CAP FLUSH WITH END OF PANEL. THE BOTTOM LEG SHOULD EXTEND OVER TOP OF THE EAVE PLATE AND BE FASTENED INTO THE EAVE PLATE WITH (2) H1020 FASTENERS.

APPLY 3/4" TAPE MASTIC (H3000) ALONG THE TOP OF THE END CAP AS SHOWN.

THE CONSTRUCTION JOINT COVER SHOULD EXTEND TO BE FLUSH WITH END CAP. FASTEN WITH (4) H1050 FASTENERS.

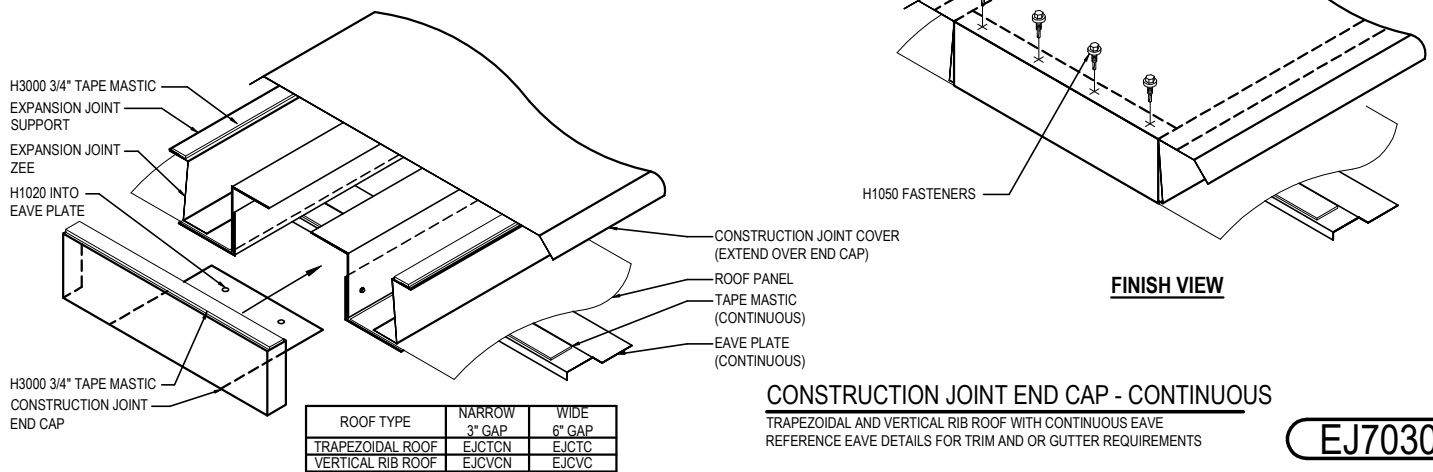

ROOF TYPE	NARROW 3" GAP	WIDE 6" GAP
TRAPEZOIDAL ROOF	EJCTCN	EJCTC
VERTICAL RIB ROOF	EJCVCN	EJCVC

CONSTRUCTION JOINT END CAP - CONTINUOUS

TRAPEZOIDAL AND VERTICAL RIB ROOF WITH CONTINUOUS EAVE
REFERENCE EAVE DETAILS FOR TRIM AND OR GUTTER REQUIREMENTS

EJ7030

Detailer Notes:

- 1) THIS DETAIL WORKS FOR BOTH TRAP & VERTICAL RIB ROOF SYSTEMS.

EJ7036 - CONSTRUCTION JOINT END CAP - OFFSET

[Download the DWG file by clicking here.](#)

INSTALLATION NOTES

INSTALL THE CONSTRUCTION JOINT SUPPORT AND ZEE MEMBERS AS INDICATED IN THE CONSTRUCTION JOINT DETAIL. MAKE SURE THAT THE MASTIC OVER THE EAVE PLATE AND UNDER THE ROOF PANEL RUN CONTINUOUS THROUGH THE JOINT AREA. IF NOT, ADD MASTIC ACROSS EAVE PLATE.

INSTALL END CAP FLUSH WITH END OF PANEL. THE BOTTOM LEG SHOULD EXTEND OVER TOP OF THE EAVE PLATE AND BE FASTENED INTO THE EAVE PLATE WITH (2) H1020 FASTENERS. ATTACH THE EJC_E TO THE VERTICAL LEG OF THE RAKE ANGLE WITH (1) H1030 FASTENER.

APPLY 3/4" TAPE MASTIC (H3000) ALONG THE TOP OF THE END CAPS AS SHOWN.

THE CONSTRUCTION JOINT COVER SHOULD EXTEND OVER THE LOWER TRIM WITH MASTIC BETWEEN. FASTEN WITH (4) H1050 FASTENERS INTO THE CAP. DO NOT FASTEN INTO THE LOWER RAKE TRIM AS IT MAY BE REQUIRED TO FLOAT. THE COVER CAN SIMPLY EXTEND OVER THE RAKE TRIM WITH A TRAPEZOIDAL ROOF SYSTEM. IF THE ROOF SYSTEM IS A VERTICAL RIB ROOF THERE WILL BE ADDITIONAL FIELD WORK REQUIRED TO BEND AND TAB THE COVER TO TRANSITION TO THE RAKE TRIM.

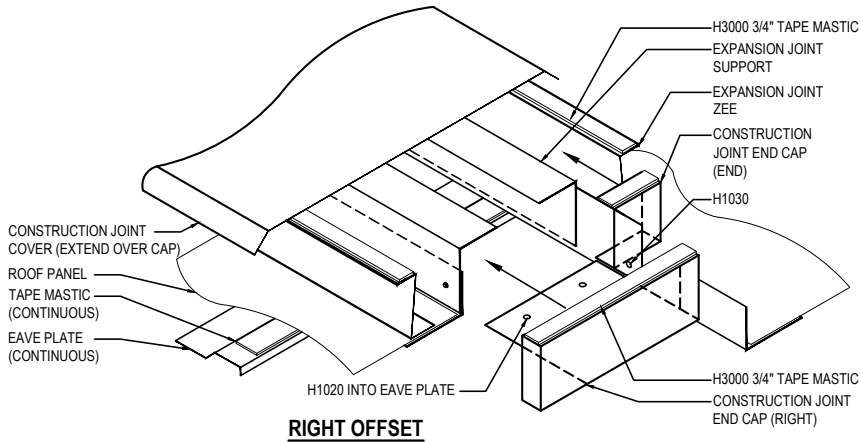

RIGHT OFFSET

ROOF TYPE	LEFT OFFSET		RIGHT OFFSET		END
	WIDE 6" GAP	NARROW 3" GAP	WIDE 6" GAP	NARROW 3" GAP	
TRAPEZOIDAL ROOF	EJCTL	EJCTLN	EJCTR	EJCTRN	EJCTE
VERTICAL RIB ROOF	EJCVL	EJCVLN	EJCVR	EJCVRN	EJCVE

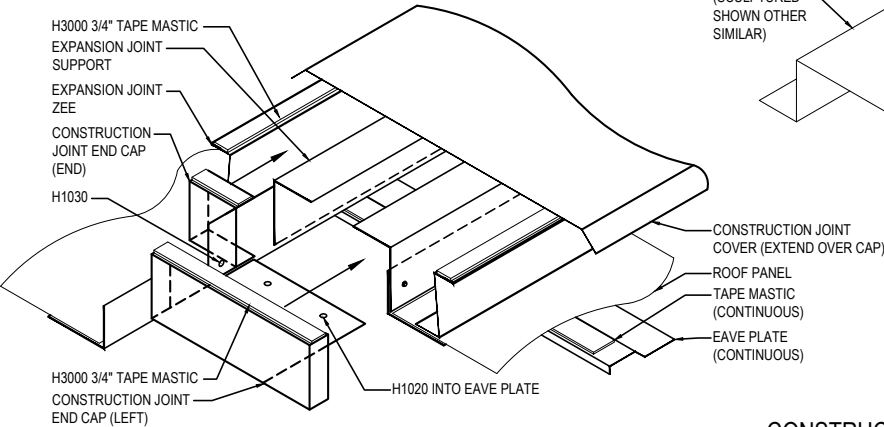

LEFT OFFSET

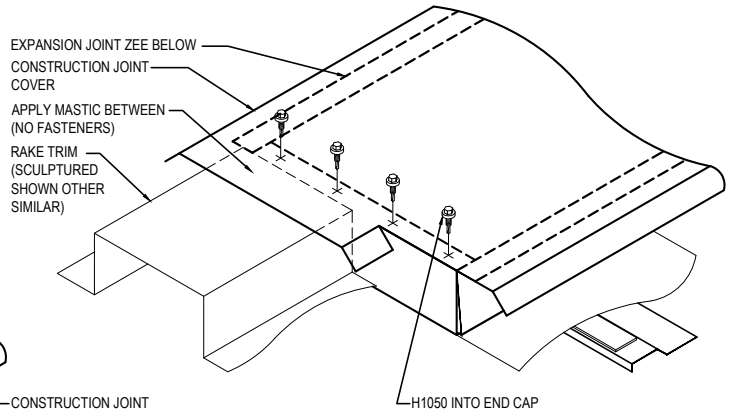

TRANSITION FINISH VIEW

CONSTRUCTION JOINT END CAP - OFFSET

TRAPEZOIDAL AND VERTICAL RIB ROOF WITH CONTINUOUS EAVE
REFERENCE EAVE DETAILS FOR TRIM AND OR GUTTER REQUIREMENTS

EJ7036

Detailer Notes:

- 1) THIS DETAIL WORKS FOR BOTH TRAP & VERTICAL RIB ROOF SYSTEMS.

EJ7037 - CONSTRUCTION JOINT TERMINATION - HE & RIDGE

[Download the DWG file by clicking here.](#)

INSTALLATION NOTES

INSTALL THE CONSTRUCTION JOINT SUPPORT AND ZEE MEMBERS AS INDICATED IN THE CONSTRUCTION JOINT DETAIL. THESE MEMBERS ALONG WITH THE COVER WILL EXTEND TO THE END OF THE ROOF PANEL..

THE PANEL CLOSURES AT THE HIGH SIDE WILL INSTALL AS THE TYPICAL CLOSURES FOR THE REST OF THE PANELS.

APPLY **TAPE MASTIC** ALONG THE TOP OF THE END COVER AS SHOWN. THIS MASTIC IS THE SAME AS THE TYPICAL HIGH EAVE OR RIDGE CONDITION AND MUST JOIN WITH THE MASTIC OVER THE PANEL CLOSURES.

INSTALL RIDGE OR HIGH EAVE OVER TOP OF THE COVER FOLLOWING THE STANDARD FASTENER SPACING FOR THOSE TYPICAL DETAILS.

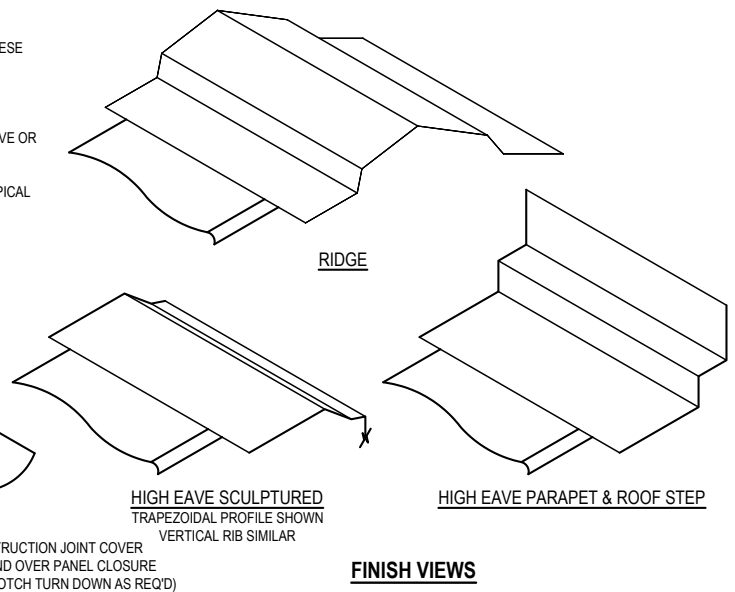
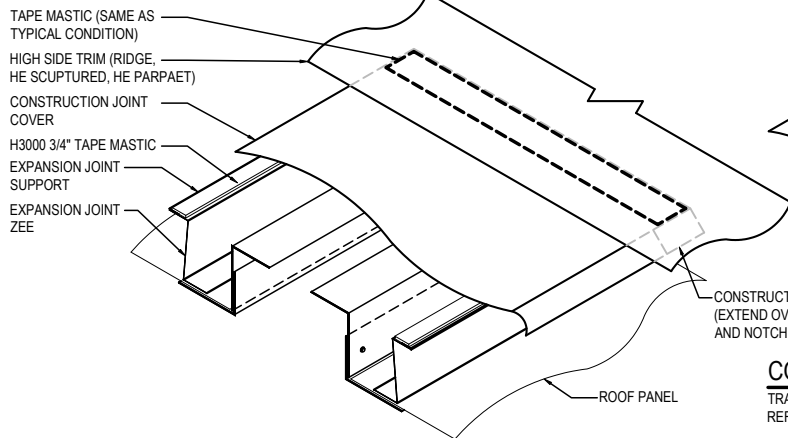

FINISH VIEWS

CONSTRUCTION JOINT TERMINATION

TRAPEZOIDAL AND VERTICAL RIB ROOF WITH HIGH EAVE OR RIDGE TRIM
 REFERENCE EAVE DETAILS FOR TRIM REQUIREMENTS

EJ7037

Detailer Notes:

- 1) THIS DETAIL WORKS FOR BOTH TRAP & VERTICAL RIB ROOF SYSTEMS.

EJ7040 - EXPANSION JOINT END CAP - CONTINUOUS

[Download the DWG file by clicking here.](#)

INSTALLATION NOTES

INSTALL THE EXPANSION JOINT SUPPORT AND ZEE MEMBERS AS INDICATED IN THE EXPANSION JOINT DETAIL. MAKE SURE THAT THE MASTIC OVER THE EAVE PLATE AND UNDER THE ROOF PANEL RUN CONTINUOUS INTO THE JOINT AREA. **NOTE: THE EAVE PLATE CANNOT BRIDGE THE GAP OF THE SECONDARY MEMBERS. THIS WILL NOT ALLOW PROPER MOVEMENT OF THE BUILDING.**

INSTALL END CAP FLUSH WITH END OF PANEL. THE BOTTOM LEG SHOULD EXTEND OVER TOP OF THE EAVE PLATE AND BE FASTENED INTO THE EAVE PLATE WITH (2) H1020 FASTENERS **ONLY ON ONE SIDE OF THE GAP IN THE EAVE PLATE TO ALLOW EXPANSION.**

APPLY 3/4" TAPE MASTIC (H3000) ALONG THE TOP OF THE END CAP AS SHOWN.

THE EXPANDO FLASH SHOULD EXTEND BEYOND THE END CAP ENOUGH TO BEND DOWN OVER THE END CAP. REMOVE THE FOAM BACKING FROM THE MEMBRANE. SLIT MEMBRANE AS REQUIRED TO LAY FLAT AGAINST END CAP. TAB METAL WING TO FOLD BACK AGAINST ZEE. SEAL MEMBRANE TO CAP WITH (H3152) POLYURETHANE CAULK. PLACE MASTIC BETWEEN TAB AND ZEE. FASTEN WITH H1050 FASTENERS AS SHOWN.

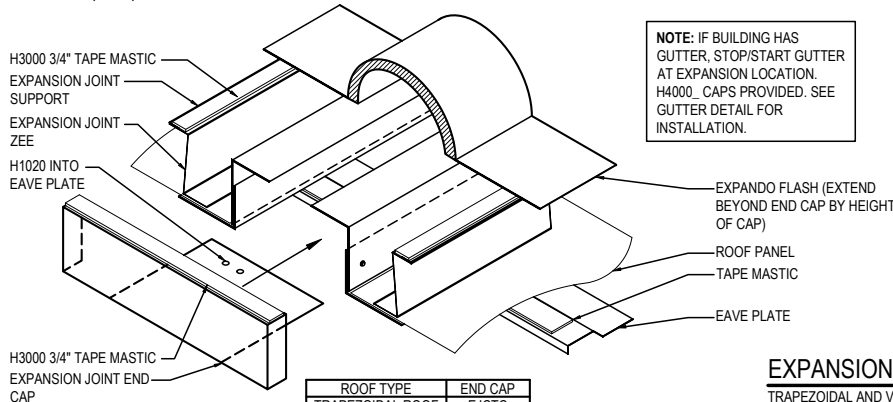

NOTE: IF BUILDING HAS GUTTER, STOP/START GUTTER AT EXPANSION LOCATION. H4000 CAPS PROVIDED. SEE GUTTER DETAIL FOR INSTALLATION.

ROOF TYPE	END CAP
TRAPEZOIDAL ROOF	EJCTC
VERTICAL RIB ROOF	EJCVK

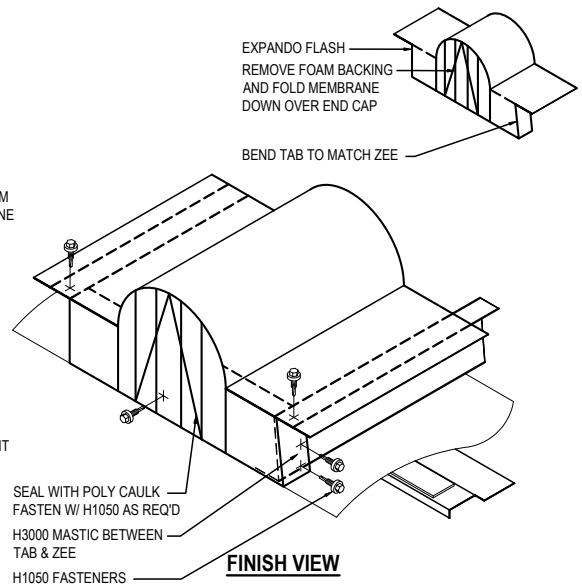

EXPANSION JOINT END CAP - CONTINUOUS

TRAPEZOIDAL AND VERTICAL RIB ROOF WITH CONTINUOUS EAVE
REFERENCE EAVE DETAILS FOR TRIM AND OR GUTTER REQUIREMENTS
IF YOU HAVE A ROOF STEP CONDITION REFERENCE EJ7050 PRIOR TO INSALLATION

EJ7040

Detailer Notes:

- 1) THIS DETAIL WORKS FOR BOTH TRAP & VERTICAL RIB ROOF SYSTEMS.

EJ7044 - EXPANSION JOINT END CAP - OFFSET

[Download the DWG file by clicking here.](#)

INSTALLATION NOTES

INSTALL THE EXPANSION JOINT SUPPORT AND ZEE MEMBERS AS INDICATED IN THE EXPANSION JOINT DETAIL. MAKE SURE THAT THE MASTIC OVER THE EAVE PLATE AND UNDER THE ROOF PANEL RUN CONTINUOUS INTO THE JOINT AREA.
NOTE: THE EAVE PLATE CANNOT BRIDGE THE GAP OF THE SECONDARY MEMBERS. THIS WILL NOT ALLOW PROPER MOVEMENT OF THE BUILDING.

INSTALL END CAP FLUSH WITH END OF PANEL. THE BOTTOM LEG SHOULD EXTEND OVER TOP OF THE EAVE PLATE AND BE FASTENED INTO THE EAVE PLATE WITH (2) H1020 FASTENERS ONLY ON ONE SIDE OF THE GAP IN THE EAVE PLATE TO ALLOW EXPANSION. ATTACH THE EJC_E TO THE VERTICAL LEG OF THE RAKE ANGLE WITH (1) H1030 FASTENER.

APPLY 3/4" TAPE MASTIC (H3000) ALONG THE TOP OF THE END CAP AS SHOWN.

THE EXPANDO FLASH SHOULD EXTEND OVER THE RAKE TRIM. THE METAL WING SHOULD HAVE MASTIC BETWEEN IT AND THE RAKE TRIM. DO NOT FASTEN INTO THE LOWER RAKE TRIM AS IT MAY BE REQUIRED TO FLOAT. THE WING CAN SIMPLY EXTEND OVER THE RAKE TRIM WITH A TRAPEZOIDAL ROOF SYSTEM. IF THE ROOF SYSTEM IS A VERTICAL RIB ROOF THERE WILL BE ADDITIONAL FIELD WORK REQUIRED TO BEND AND TAB THE WING TO TRANSITION TO THE RAKE TRIM. REMOVE THE FOAM BACKING FROM THE MEMBRANE. SLIT MEMBRANE AS REQUIRED TO LAY FLAT AGAINST RAKE TRIM AND CAP.

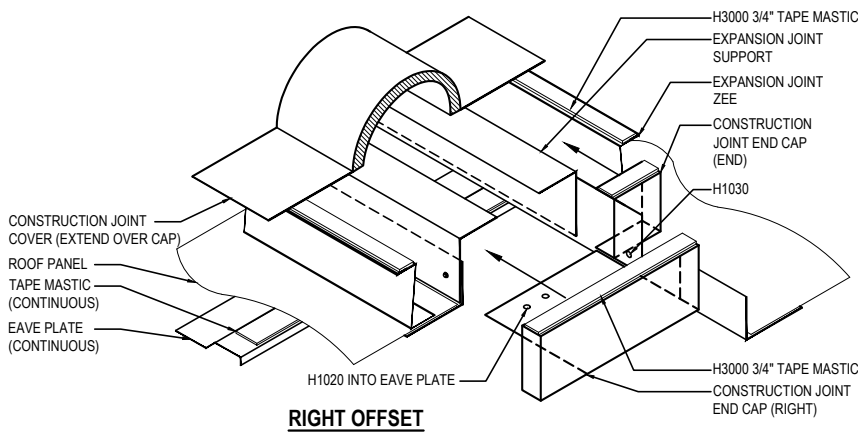

RIGHT OFFSET

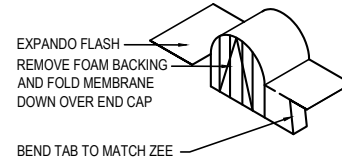

ROOF TYPE	LEFT OFFSET	RIGHT OFFSET	END
TRAPEZOIDAL ROOF	EJCTL	EJCTR	EJCTE
VERTICAL RIB ROOF	EJCVL	EJCVR	EJCVE

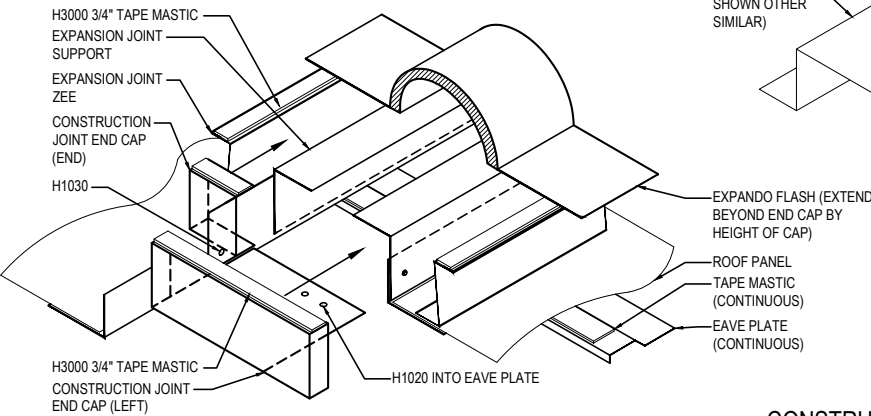

LEFT OFFSET

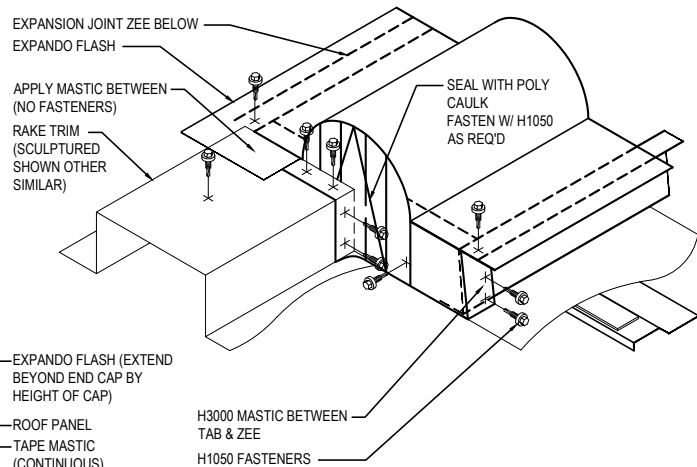

TRANSITION FINISH VIEW

CONSTRUCTION JOINT END CAP - OFFSET

TRAPEZOIDAL AND VERTICAL RIB ROOF WITH CONTINUOUS EAVE
REFERENCE EAVE DETAILS FOR TRIM AND OR GUTTER REQUIREMENTS

EJ7044

Detailer Notes:

- 1) THIS DETAIL WORKS FOR BOTH TRAP & VERTICAL RIB ROOF SYSTEMS.

EJ7046 - EXPANSION JOINT SPLICE

[Download the DWG file by clicking here.](#)

- ALIGN THE ENDS OF THE EXPANDO FLASH AND ENSURE THEY MATCH EACH OTHER WITH NO GAP AS SHOWN. **CLEAN AREA THOROUGHLY** PRIOR TO APPLYING PRIMER. APPLY THE INCLUDED **PRIMER** IN THE SPLICE KIT WITH A SMALL BRUSH ON THE METAL WINGS AND MEMBRANE. USE THE **SPLICE TAB** FROM THE KIT TO DETERMINE AREA TO APPLY PRIMER. **THE PRIMER WILL GO ON SHINNY. ALLOW PRIMER TO DRY TO TACK FREE.**

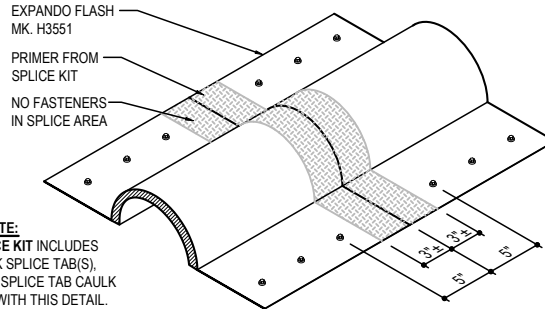

ERECTOR NOTE:
H3551K SPLICE KIT INCLUDES PEEL 'N STICK SPLICE TAB(S), PRIMER, AND SPLICE TAB CAULK TO BE USED WITH THIS DETAIL.

- PEEL THE **SPLICE TAB** AWAY FROM BACKING AND APPLY CENTERED OVER THE BUTT JOINT OF THE EXPANDO FLASH MATERIAL. **DO NOT STRETCH** THE SPLICE TAB AND WORK IT INTO THE CREVICES. THERE SHOULD BE NO GAPS IN THE CREVICES WHERE THE MEMBRANE MEETS THE METAL WINGS. ANY GAPS ARE POTENTIAL WATER INFILTRATION AREAS. INSTALL **FASTENERS THROUGH SPLICE TAB** AS SHOWN ON BOTH SIDES TO PREVENT EXPANDO FLASH FROM CURLING.

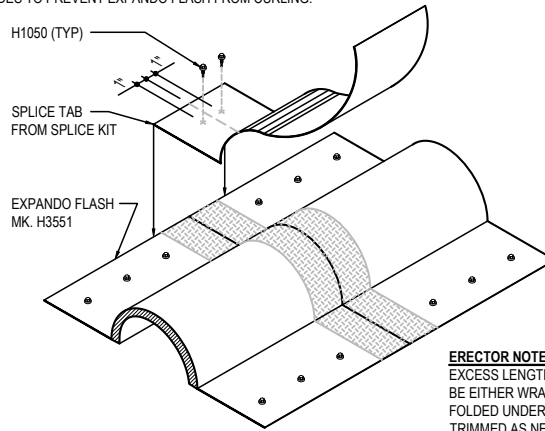

ERECTOR NOTE:
EXCESS LENGTH OF TAB CAN BE EITHER WRAPPED AND FOLDED UNDER WING OR TRIMMED AS NEEDED

- APPLY **1/4" BEAD OF SUPPLIED TAB CAULK 1" LONG** IN ALL FOUR CORNERS AS SHOWN. TROWEL THE CAULK TOWARD SPLICE TAB TO FILL ALL POTENTIAL GAPS BETWEEN SPLICE TAB AND EXPANDO FLASH.

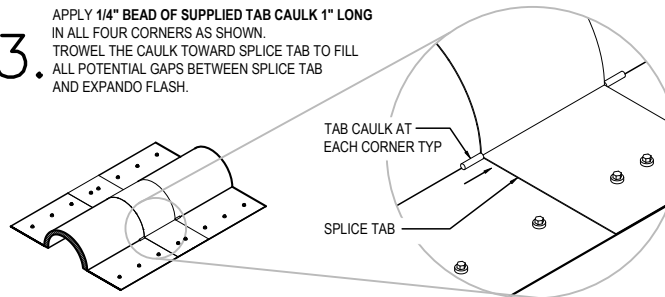

EXPANSION JOINT SPLICE

TYPICAL SPLICE FOR EXPANDO FLASHING AT SPLICES AND TRANSITION TO PROFILED TERMINATIONS.

EJ7046

Detailer Notes:

- 1) THIS DETAIL WORKS FOR BOTH TRAP & VERTICAL RIB ROOF SYSTEMS.
- 2) THIS DETAIL SHOULD ALWAYS BE SUPPLIED WHEN EXPANDO FLASH EXPANSION DETAILS ARE USED.

EJ7047 - EXPANSION JOINT TERMINATION - RIDGE

[Download the DWG file by clicking here.](#)

ROOF TYPE	EXPANDO FLASH - RIDGE
TRAPEZOIDAL ROOF	EJEFR
VERTICAL RIB ROOF	EJEFRV

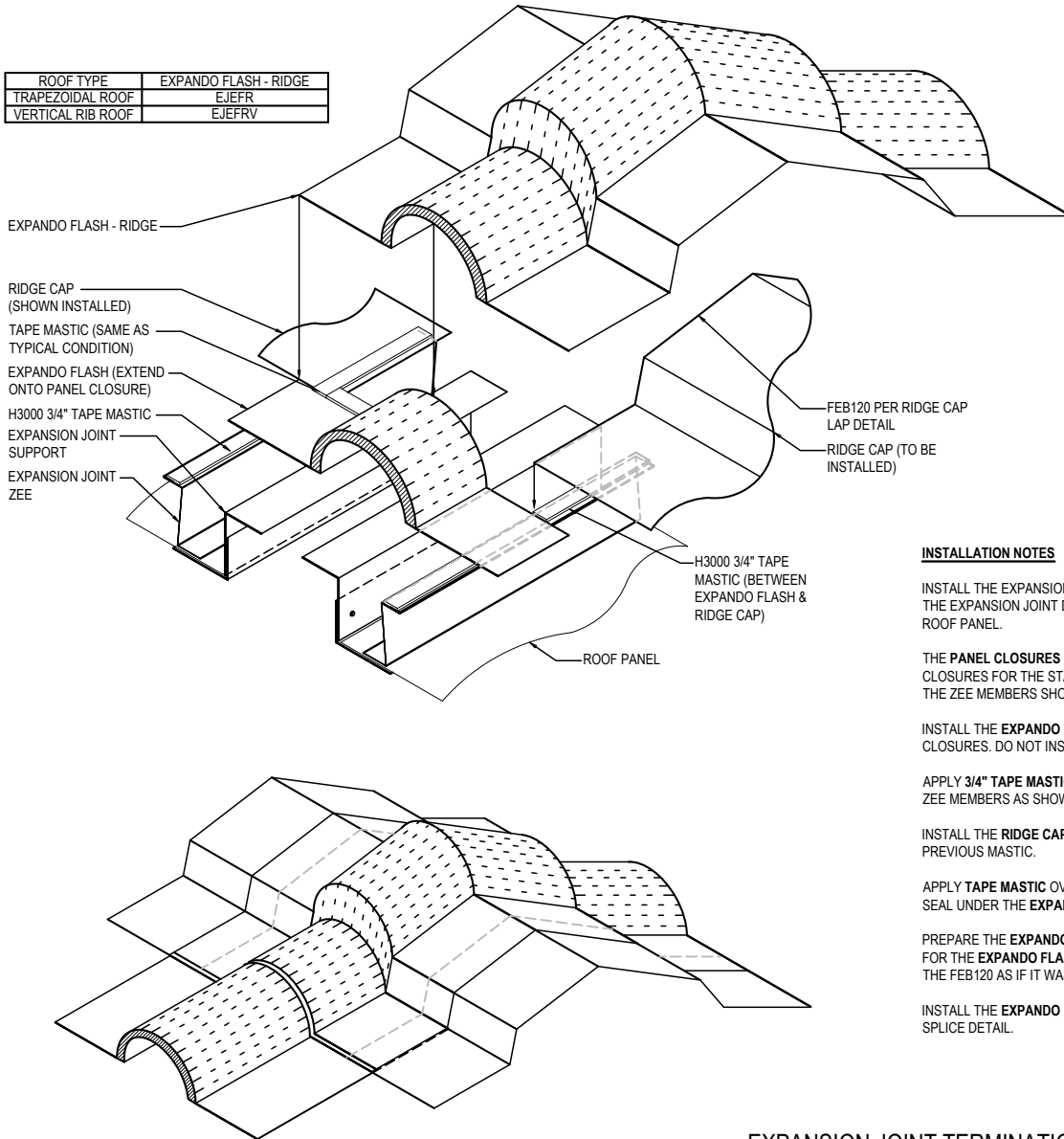

FINISH VIEW

INSTALLATION NOTES

INSTALL THE EXPANSION JOINT **SUPPORT AND ZEE MEMBERS** AS INDICATED IN THE EXPANSION JOINT DETAIL. THESE MEMBERS WILL EXTEND TO THE END OF THE ROOF PANEL.

THE **PANEL CLOSURES** AT THE HIGH SIDE WILL INSTALL AS THE TYPICAL CLOSURES FOR THE START OR FINISH PANELS. THE **3/4\"**

INSTALL THE **EXPANDO FLASH** TO EXTEND TO TOP EDGE OF THE PANEL CLOSURES. DO NOT INSTALL FASTENERS WHERE THE RIDGE CAP WILL COVER.

APPLY **3/4\"**

INSTALL THE **RIDGE CAP** OVER TOP OF THE **EXPANDO FLASH** AND SEAT INTO THE PREVIOUS MASTIC.

APPLY **TAPE MASTIC** OVER THE **RIDGE CAP / EXPANDO FLASH WING** AS SHOWN TO SEAL UNDER THE **EXPANDO FLASH RIDGE** PIECE.

PREPARE THE **EXPANDO FLASH RIDGE** PIECE ACCORDING THE SPLICE DETAILS FOR THE **EXPANDO FLASH**. ALSO PREPARE THE ENDS OF THE **RIDGE CAP** AS WITH THE FEB120 AS IF IT WAS A LAP IN THE RIDGE DETAIL.

INSTALL THE **EXPANDO FLASH RIDGE** PIECE AND FASTEN SAME AS THE RIDGE CAP SPLICE DETAIL.

EXPANSION JOINT TERMINATION

TRAPEZOIDAL AND VERTICAL RIB ROOF AT RIDGE CAP
REFERENCE RIDGE DETAILS FOR TRIM REQUIREMENTS

EJ7047

Detailer Notes:

- 1) THIS DETAIL WORKS FOR BOTH TRAP & VERTICAL RIB ROOF SYSTEMS.

EJ7048 - EXPANSION JOINT TERMINATION - HE PARAPET

[Download the DWG file by clicking here.](#)

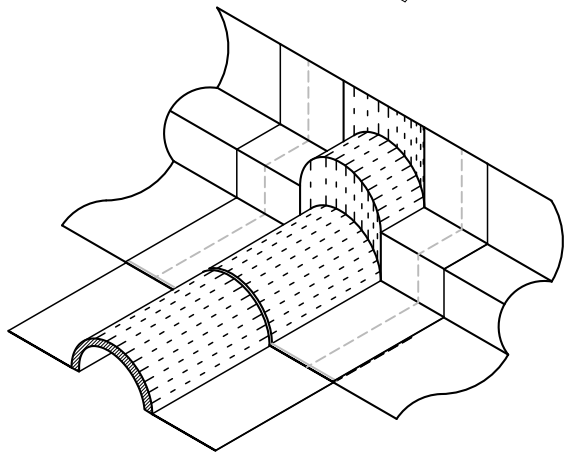
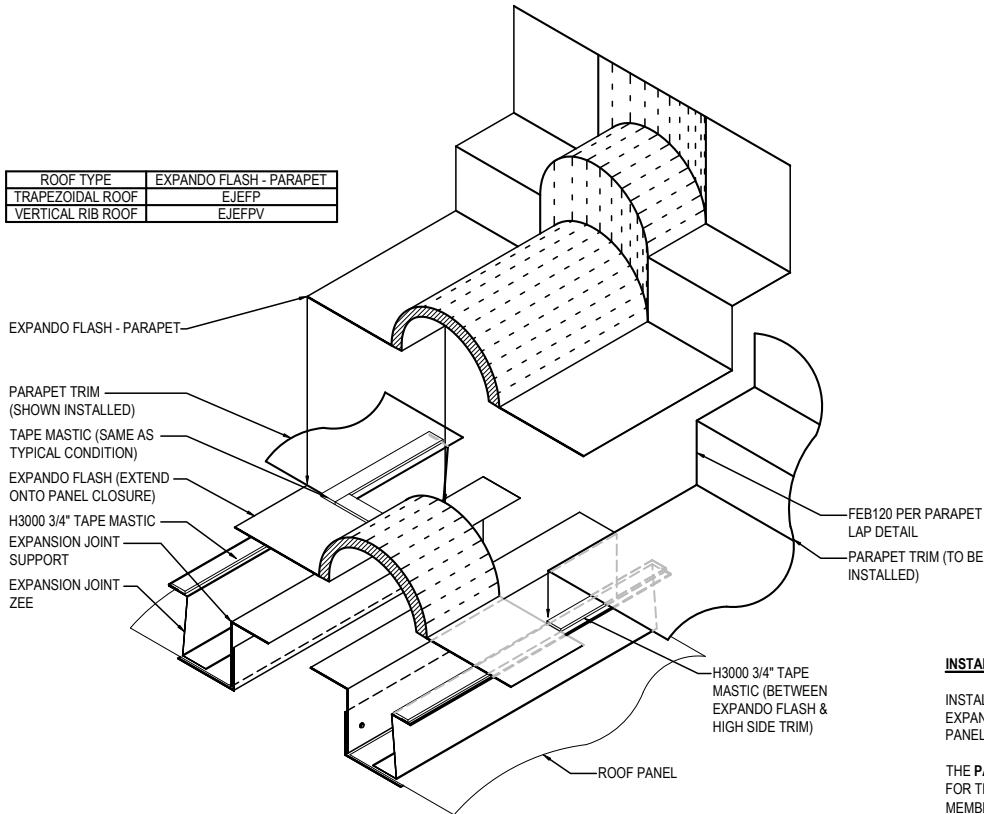

FINISH VIEW

INSTALLATION NOTES

- INSTALL THE EXPANSION JOINT **SUPPORT AND ZEE MEMBERS** AS INDICATED IN THE EXPANSION JOINT DETAIL. THESE MEMBERS WILL EXTEND TO THE END OF THE ROOF PANEL.
- THE **PANEL CLOSURES** AT THE HIGH SIDE WILL INSTALL AS THE TYPICAL CLOSURES FOR THE START OR FINISH PANELS. THE **3/4\" TAPE MASTIC** ON TOP OF THE ZEE MEMBERS SHOULD EXTEND TO TOP EDGE OF PANEL CLOSURES.
- INSTALL THE **EXPANDO FLASH** TO EXTEND TO TOP EDGE OF THE PANEL CLOSURES. DO NOT INSTALL FASTENERS WHERE THE RIDGE CAP WILL COVER.
- APPLY **3/4\" TAPE MASTIC** OVER THE EXPANDO FLASH WING DIRECTLY ABOVE THE ZEE MEMBERS AS SHOWN. THIS WILL SEAL RIDGE CAP TO THE EXPANDO FLASH.
- INSTALL THE **PARAPET TRIM** OVER TOP OF THE **EXPANDO FLASH** AND SEAT INTO THE PREVIOUS MASTIC.
- APPLY **TAPE MASTIC** OVER THE **PARAPET TRIM / EXPANDO FLASH WING** AS SHOWN TO SEAL UNDER THE **EXPANDO FLASH RIDGE** PIECE.
- PREPARE THE **EXPANDO FLASH PARAPET** PIECE ACCORDING THE SPLICE DETAILS FOR THE **EXPANDO FLASH**. ALSO PREPARE THE ENDS OF THE **PARAPET TRIM** AS WITH THE **FEB120** AS IF IT WAS A LAP IN THE RIDGE DETAIL.
- INSTALL THE **EXPANDO FLASH PARAPET** PIECE AND FASTEN SAME AS THE PARAPET TRIM SPLICE DETAIL.

EXPANSION JOINT TERMINATION

TRAPEZOIDAL AND VERTICAL RIB ROOF WITH HIGH EAVE PARAPET TRIM
REFERENCE HIGH EAVE PARAPET DETAILS FOR TRIM REQUIREMENTS

EJ7048

Detailer Notes:

- 1) THIS DETAIL WORKS FOR BOTH TRAP & VERTICAL RIB ROOF SYSTEMS.

EJ7049 - EXPANSION JOINT TERMINATION - HE SCULPTURED

[Download the DWG file by clicking here.](#)

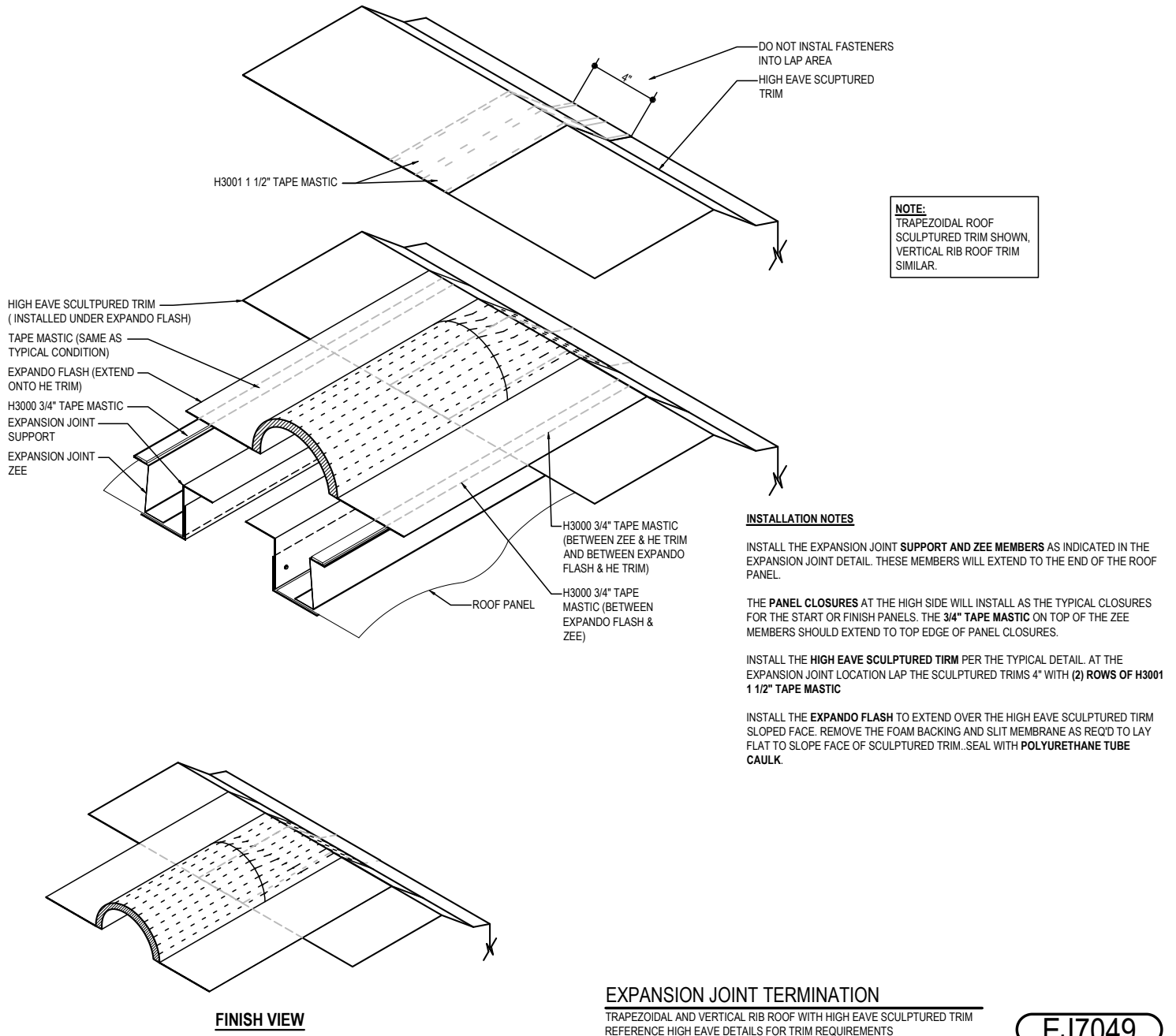

Detailer Notes:

- 1) THIS DETAIL WORKS FOR BOTH TRAP & VERTICAL RIB ROOF SYSTEMS.

EJ7050 - EXPANSION JOINT TERMINATION - ROOF STEP

[Download the DWG file by clicking here.](#)

ROOF TYPE	EXPANDO FLASH - PARAPET
TRAPEZOIDAL ROOF	EJEFP
VERTICAL RIB ROOF	EJFPV

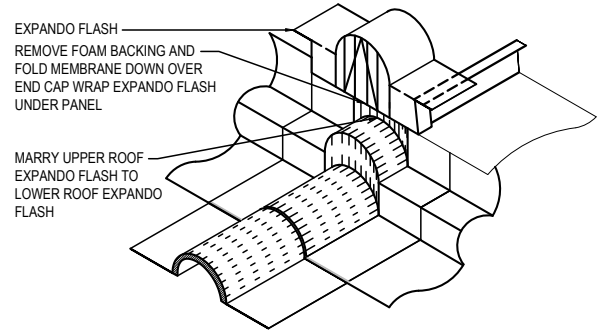
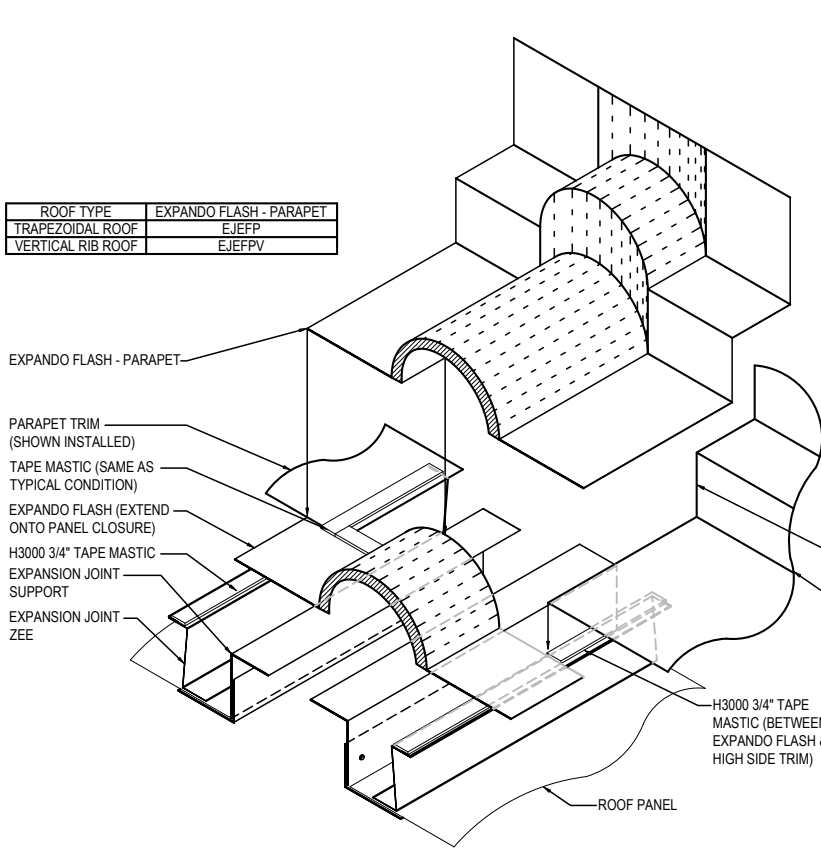

FINISH VIEW WITH UPPER ROOF INSTALL
REFERENCE LOW EAVE CONDITION FOR END CAP INSTALL

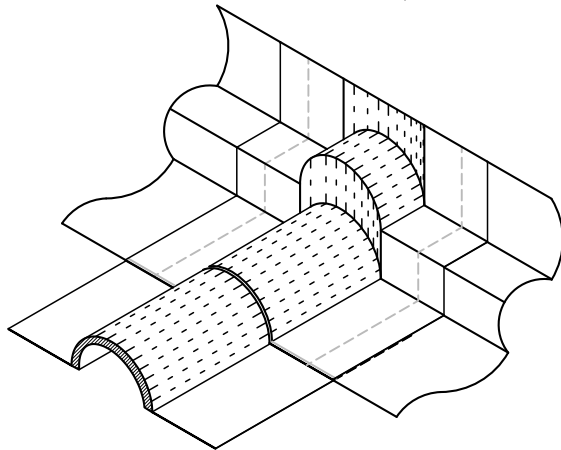

FINISH VIEW PRIOR TO UPPER ROOF INSTALL

FEB120 PER PARAPET LAP DETAIL
PARAPET TRIM (TO BE INSTALLED)

INSTALLATION NOTES

INSTALL THE EXPANSION JOINT **SUPPORT AND ZEE MEMBERS** AS INDICATED IN THE EXPANSION JOINT DETAIL. THESE MEMBERS WILL EXTEND TO THE END OF THE ROOF PANEL.

THE **PANEL CLOSURES** AT THE HIGH SIDE WILL INSTALL AS THE TYPICAL CLOSURES FOR THE START OR FINISH PANELS. THE **3/4\"/>**

INSTALL THE **EXPANDO FLASH** TO EXTEND TO TOP EDGE OF THE PANEL CLOSURES. DO NOT INSTALL FASTENERS WHERE THE RIDGE CAP WILL COVER.

APPLY **3/4\"/>**

INSTALL THE **PARAPET TRIM** OVER TOP OF THE **EXPANDO FLASH** AND SEAT INTO THE PREVIOUS MASTIC.

APPLY **TAPE MASTIC** OVER THE **PARAPET TRIM / EXPANDO FLASH WING** AS SHOWN TO SEAL UNDER THE **EXPANDO FLASH RIDGE** PIECE.

PREPARE THE **EXPANDO FLASH PARAPET** PIECE ACCORDING THE SPLICE DETAILS FOR THE **EXPANDO FLASH**. ALSO PREPARE THE ENDS OF THE **PARAPET TRIM** AS WITH THE **FEB120** AS IF IT WAS A LAP IN THE RIDGE DETAIL.

INSTALL THE **EXPANDO FLASH PARAPET** PIECE AND FASTEN SAME AS THE PARAPET TRIM SPLICE DETAIL.

EXPANSION JOINT TERMINATION

TRAPEZOIDAL AND VERTICAL RIB ROOF WITH HIGH EAVE PARAPET TRIM
REFERENCE HIGH EAVE PARAPET DETAILS FOR TRIM REQUIREMENTS

EJ7050

Detailer Notes:

- 1) THIS DETAIL WORKS FOR BOTH TRAP & VERTICAL RIB ROOF SYSTEMS.

EJ7150 - ROOF STEP TERMINATION

[Download the DWG file by clicking here.](#)

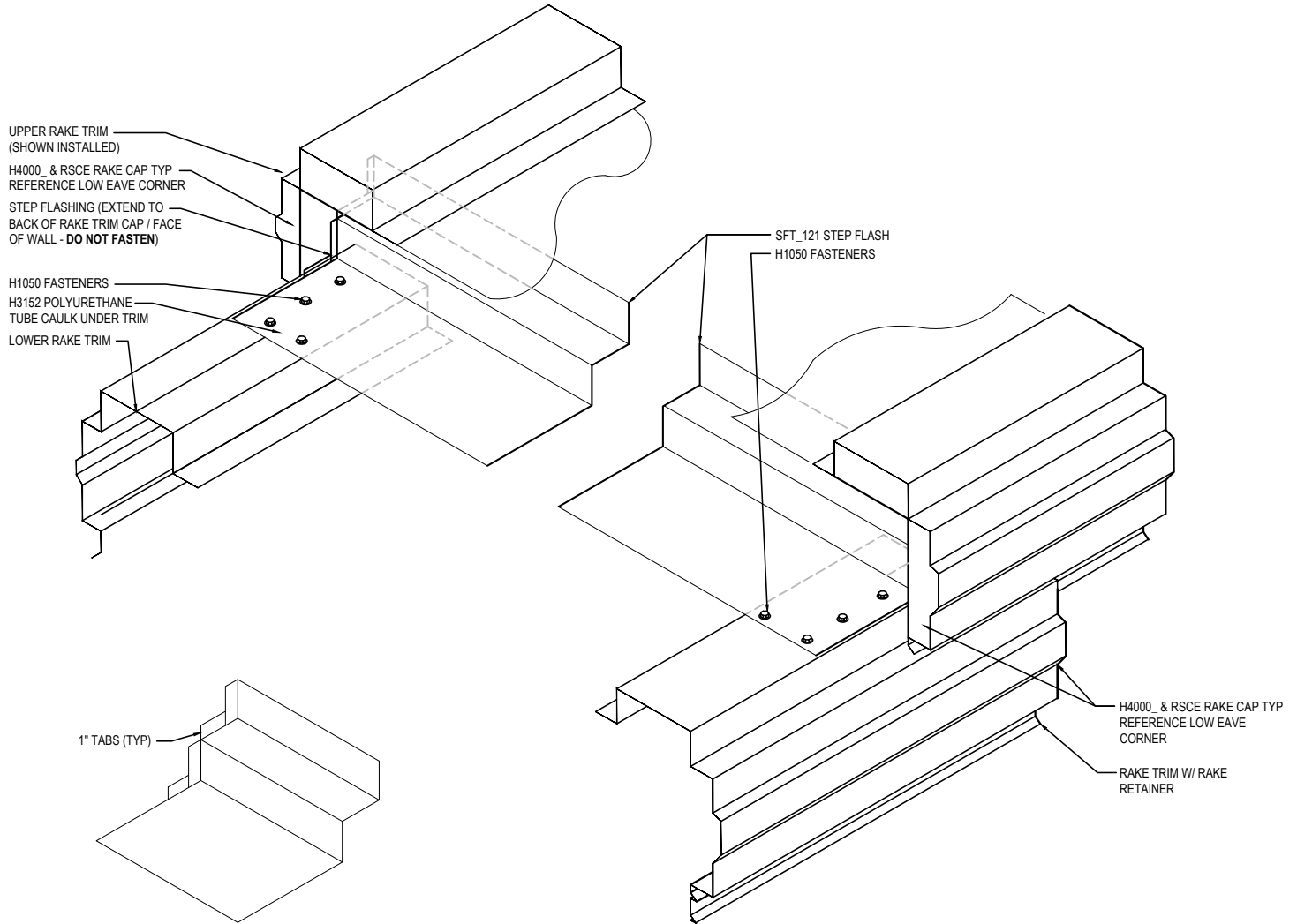

TABBED VIEW

INSTALLATION NOTES

INSTALLATION IS EASIER IF THE LOWER ROOF IS INSTALLED FIRST ALONG WITH THE EAVE PLATE OF THE UPPER ROOF. THE UPPER ROOF PANEL CAN BE INSTALLED PRIOR TO THE STEP FLASH BUT DOES MAKE INSTALLATION MORE CHALLENGING AND TIGHTER SPACES.

THE **LOWER RAKE TRIM** MUST BE INSTALLED PRIOR TO THE FIRST/LAST PIECE OF STEP FLASH. LOWER RAKE TRIM **EXTENDS 3"** BEYOND THE END OF THE ROOF PANEL.

THE FIRST AND LAST PIECE OF **STEP FLASHING** WILL NEED TO BE **FIELD TABBED** AS SHOWN.

SEAL THE **STEP FLASH** TO THE VERTICAL FACE OF THE STEP ANGLE AS SHOWN IN THE TYPICAL ROOF STEP DETAIL. SEAL THE HORIZONTAL LEG OF THE STEP FLASH TO THE LOWER RAKE TRIM WITH **POLYURETHANE TUBE CAULK (H1352)** AND FASTENERS AS SHOWN.

ROOF STEP TERMINATION

VERTICAL RIB ROOF WITH SCULPTURED RAKE TRIM
REFERENCE TYPICAL ROOF STEP DETAIL FOR FURTHER INFORMATION

EJ7150

Detailer Notes:

- 1) THIS DETAIL WORKS FOR BOTH TRAP & VERTICAL RIB ROOF SYSTEMS.